

Rayleigh rejection trade study report  
Version 1.0

*V. Velur*<sup>1</sup>, *A. Bouchez*<sup>1</sup>, *C. Neyman*<sup>2</sup> and *D. Gavel*<sup>3</sup>  
*Caltech Optical Observatories*<sup>1</sup>  
*W. M. Keck Observatory*<sup>2</sup>  
*UCO Lick Observatory*<sup>3</sup>

June 15, 2007

# Contents

<b>1</b>	<b>Introduction</b>	<b>4</b>
1.1	WBS definition . . . . .	4
1.1.1	EC's suggestion after meeting #3 . . . . .	4
<b>2</b>	<b>LIDAR equation</b>	<b>5</b>
2.1	Simulated results center projected laser for a obscured telescope . . . . .	5
<b>3</b>	<b>Laser types and pulse formats table</b>	<b>5</b>
<b>4</b>	<b>Rayleigh rejection techniques</b>	<b>8</b>
4.1	Background subtraction - based on noise model . . . . .	8
4.2	Optimizing projection location . . . . .	8
4.3	Baffles and stops . . . . .	8
<b>5</b>	<b>Fluctuations in low altitude scatter</b>	<b>10</b>
5.1	Comparison of Rayleigh scatter due to Cirrus clouds and boundary layer aerosols . . . . .	10
<b>6</b>	<b>The effect of looking through a laser beam</b>	<b>10</b>
6.1	Effect at the pupil plane . . . . .	10
6.2	Effect at the focal plane . . . . .	13
6.3	Yutaka et. al's conclusion . . . . .	13
<b>7</b>	<b>Multiple laser beacons and fratricide issue</b>	<b>13</b>
7.1	Gavel and Ellerbroek's results . . . . .	14
<b>8</b>	<b>Concluding remarks</b>	<b>14</b>

# List of Figures

1	The effect of Rayleigh scatter at the focal plane due to a single laser (with secondary obscuration) . . . . .	6
2	Sample return from Palomar data (they #s have to be anchored) . . . . .	7
3	Optimizing projector location . . . . .	9
4	Baffles and stops) . . . . .	10
5	Comparison between modeled Rayleigh scatter and measured scatter in presence of sub-visual cirrus ad boundary layer aerosols [3] . . . . .	11
6	Long term trends (effect of volcanic activity of the aerosol scatter) [4] . . . . .	12
7	Projection geometry for fratricide analysis . . . . .	14
8	Preliminary simulation of the effect of 4 beacons as seen by a sub-aperture . . . . .	15
9	Sub-aperture flux . . . . .	16
10	Results from Ellerbroek's simulation for the Gemini MCAO system . . . . .	16
11	Results from Gavel's simulation for Gemini MCAO system . . . . .	17

## List of Tables

# 1 Introduction

NGAO's baseline architecture is based on five 50W lasers used to create a quincunx-like asterism on sky to enable wide-field and high Strehl narrow field observations. To obtain useful science from the system it is important to reject Rayleigh scatter from the resonant backscatter from the LGS beacon effectively.

This trade study looks at quantifying and mitigating the effect of this unwanted scatter. As part of this study we have built a model to evaluate the Rayleigh scatter from the atmosphere, we discuss the laser options for NGAO at a basic level and looks at the various Rayleigh rejection techniques. The report looks at atmospheric scatter fluctuations over short and long time scales based on published results. Hayano et. al's results are documented to show the effect of scatter from a laser on another observatory working on the same summit. Fratricide effect for the quincunx configuration are documented from previous work by Ellerbroek and Gavel, a preliminary model has been built for more detailed analysis of the fratricide issue for the detailed design phase, results from the preliminary model are presented in this report.

## 1.1 WBS definition

3.1.2.2.5 Rayleigh Rejection: Evaluate the impact of unwanted Rayleigh backscatter to NGAO system performance. Consider the relative performance, cost, risk and schedule of various strategies for mitigation of LGS Rayleigh backscatter. Techniques include background subtraction, modulation and optimizing projection location. This issue is closely coupled to laser pulse format, with pulsed lasers generally providing more options for Rayleigh mitigation than CW lasers. Complete when NGAO baseline architecture selected.

### 1.1.1 EC's suggestion after meeting #3

- The modeling of Rayleigh return and looking at time variability is adequate and should be documented in the report. No more work should be done in this area for this WBS.
- Should review PASP paper describing the results of the Subaru observations of the Keck laser. Conclusions drawn from this report about the impact of Rayleigh, and anchoring the Lidar modeling results, should be included in the TS report.
- Should review Gemini MCAO Rayleigh Scatter Fratricide ppt presentation (Don will also look for the written report) and use the relevant information in compiling the TS report.
- The impact of the Rayleigh light contaminating the LGS wavefront sensing from a single laser should be summarized in the TS report. The pros and cons, including effectiveness, of the various potential Rayleigh rejection approaches for this single laser scenario should also be summarized.
- The impact of the Rayleigh light from one laser contaminating the LGS wavefront sensing from another laser should be summarized in the TS report. The pros and cons, including effectiveness, of the various potential Rayleigh rejection approaches for this fratricide scenario should also be summarized.

- Techniques that should be considered in the above two evaluations include background subtraction, optimizing projector location, optical baffling and modulation techniques. Additional techniques that should be considered for fratricide rejection include ignoring (or de-weighting) Rayleigh-illuminated subapertures and modulating which laser/WFS are in use at any given time.
- Should only discuss laser types in the TS report to the extent this topic impacts the Rayleigh rejection topic. Consider pulling section 3 (sodium laser types) of the proposed report format into section 5 (comparison of laser options)
- Only a very modest effort should go into any new modeling or analysis to support completing a draft TS report. Qualitative or order of magnitude comparisons are adequate for the draft. Please provide an effort estimate for any more detailed work that you feel would be appropriate, and get EC approval before proceeding.

## 2 LIDAR equation

To calculate the Rayleigh return for all simulations in this report, we use the LIDAR equation as given by Gardner [1] for the Keck telescope geometry. We assume a 50 cm laser launch telescope and the central obscuration of Keck is taken into account for the effect of the focal plane 1.

### 2.1 Simulated results center projected laser for a obscured telescope

The effect of Rayleigh scatter from a single laser beacon that is centrally projected as seen at the focal plane is shown in 1. The central dip in the flux is due to the central obscuration of the Keck telescope. Experimental data collected from Palomar is shown in 2 which also shows similar trends.

## 3 Laser types and pulse formats table

This section will be discussed in brevity and further details in LGS based trade studies and design studies. CW, CW modelocked, dye, long pulsed (200 micro-sec pulse) and short pulsed (1-3 micro-sec pulse) lasers are options for NGAO. Both CW and modelocked CW are well understood and a few of these have been field tested. Dye lasers are complex and hard to maintain and won't be considered amongst the frontrunners for NGAO laser options. The ideal lasers to mitigate fratricide effect are 1-3 micro-Sec pulsed lasers, there are a few groups trying to build a laser with this pulse format. Apart from these, there is the DARPA funded work on coherent CW diode arrays that produce 500W-1 KW of coherent laser power by phase-locking diode laser arrays. These have very high speed phase-lock electronics that can be used to tip and tilt the beam. However, due to current diode laser manufacturing techniques and because of non-availability of diodes at the required wavelength, we have to settle for yet another sum-frequency laser.

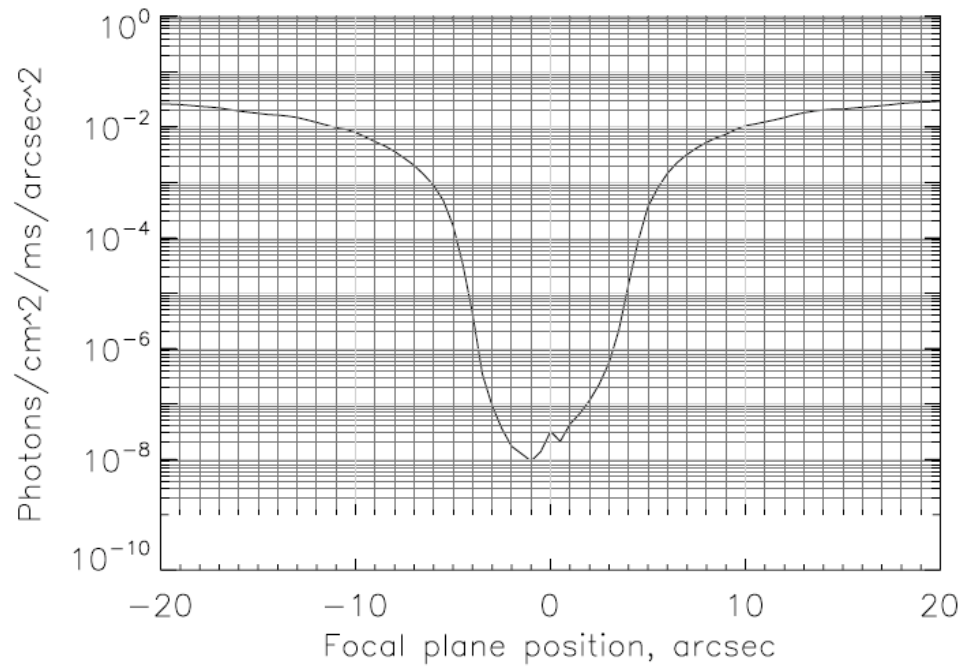

Figure 1: The effect of Rayleigh scatter at the focal plane due to a single laser (with secondary obscuration)

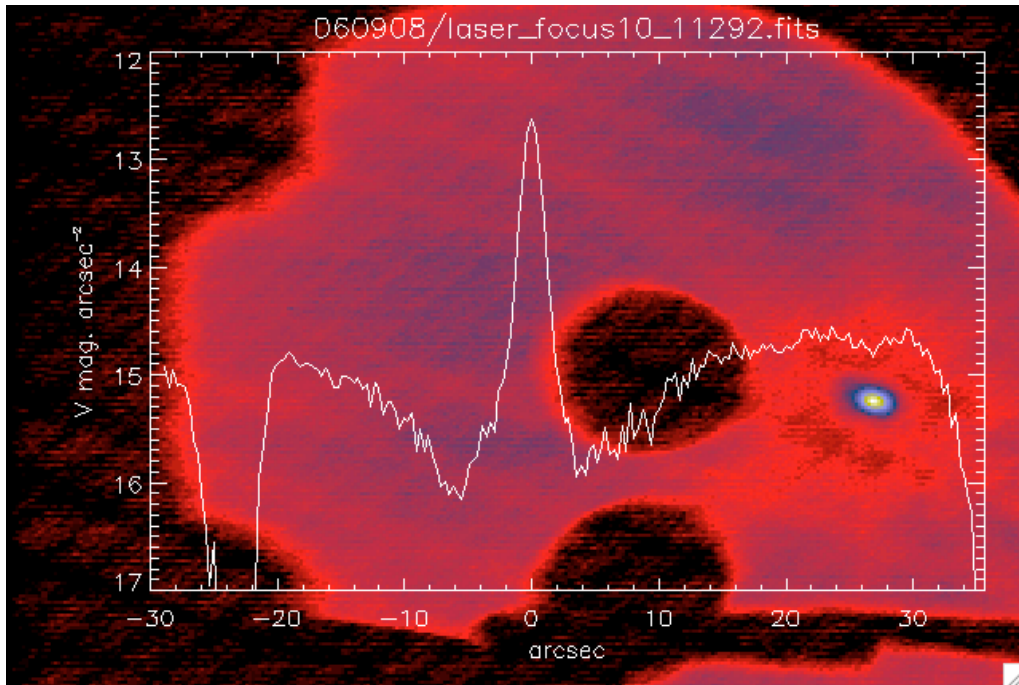

Figure 2: Sample return from Palomar data (they #s have to be anchored)

## 4 Rayleigh rejection techniques

Rayleigh rejection techniques for a quincunx configuration can be done using the following techniques:

### 4.1 Background subtraction - based on noise model

1. An accurate model of the Rayleigh scatter will yield a SNR reduction due to Rayleigh scatter at each sub-aperture by being able to quantify the same and subtracting it effectively from the signal.
2. All five WFS are affected by all Rayleigh scatter from each of the 5 lasers in a centrally projected quincunx geometry, but, the distribution of Rayleigh scatter is different in different sub-apertures and the flux distribution is different in the central and the corner WFSs.
3. We know from Hayanos measurements that 10% of the background comes from scatter due to aerosols. This has to be added as an allocation to the error budget to the Rayleigh scatter.
4. A detailed simulation of the Rayleigh background will show the effect on various sub-apertures for each wavefront sensor. Based on this (and spider obscuration) a optimal reconstructor can be created. In the worst affected sub-aperture(s), the SNR loss is about a factor of 2 based on the Gemini MCAO work done by Gavel and Ellerbroek.
5. Appropriate white noise component due to Rayleigh+ Mie scatter should also be added to the error budget. The % of affected sub-apertures is to be determined after looking at results from a more detailed simulation, but is of the order of 40% in each WFS as seen by previous work done for the Gemini MCAO system.

### 4.2 Optimizing projection location

Effective projection technique - for e.g. it is better to align the 4 off-axis beacons to the telescope spiders. The sub-apertures hidden under the spiders are naturally de-weighted in the centroiding scheme and the Rayleigh scatter from the lasers will somewhat be blocked by the spider. So we use the remaining sub-apertures effectively. It also reduces fratricide to some extent. But this can't be used for a symmetric quincunx configuration for the Keck telescope because of the spider geometry. During the choice of LGS asterism geometry and number of lasers this effect may be considered along with the advantage due to tomography.

The preferred launch point for the lasers is from the center of the telescope rather than from the sides even though some beacons will see lesser Rayleigh scatter. The spot elongation is excessively large for a side projected beacon at the sub-apertures at the far end (3 arcsec). These were the only 2 options considered for projection location in this study and qualitatively based on work done by van Dam and Clare it is suggested that we center project.

### 4.3 Baffles and stops

Rayleigh scatter on any visible detector is an unwanted and stops and baffles are necessary to minimize this source of error. Since the Rayleigh scatter is out of focus w.r.t. the light from the



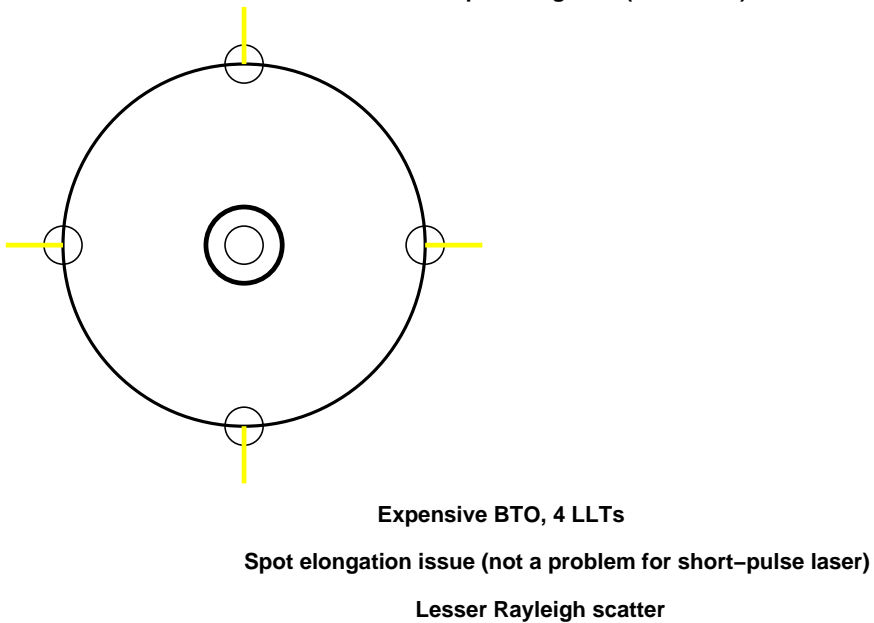
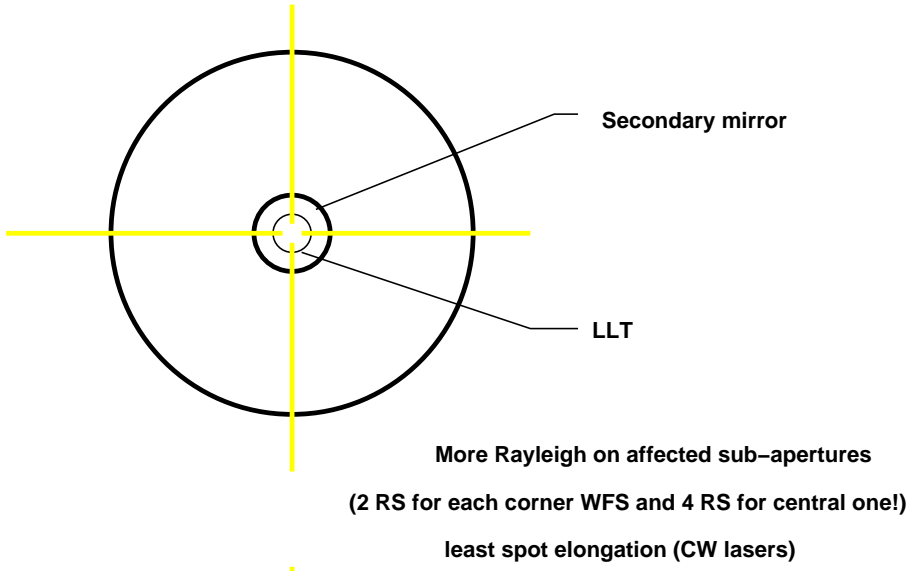
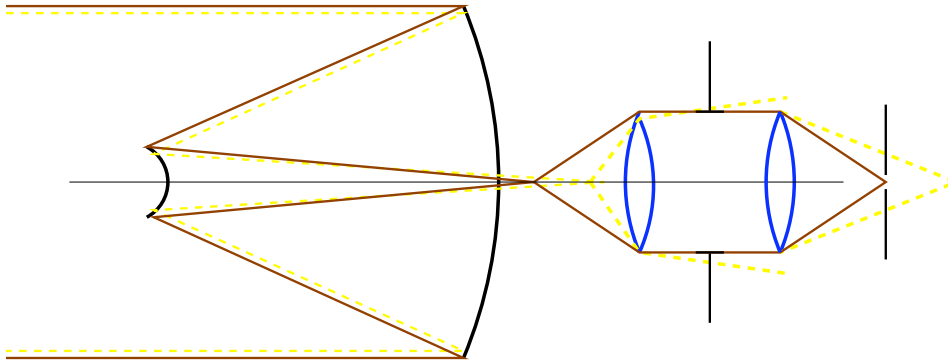

Figure 3: Optimizing projector location



Pupil stop and baffles around the optics of the AO system to prevent stray light problems  
Adjustable field stop (to prevent Rayleigh, sky and cross-talk)

Figure 4: Baffles and stops)

sodium beacon or star light, appropriate pupil stops and stops at the focal plane (such as field stops) need to be built into the optical design.

## 5 Fluctuations in low altitude scatter

Though Yutaka's paper suggests that the scatter due to aerosols (Mie scatter) is less than 10% of the Rayleigh scatter on a typical photometric night, there is literature that claim that there are much larger fluctuations in the Mie scatter. These fluctuations occur in both long term (years) and short term (minutes) time scales. The short term fluctuations are caused by cirrus clouds 5 while the long term fluctuations are associated with volcanic activity primarily 6. So some factor of safety must be allocated for this effect in the SNR calculation in the error budget.

### 5.1 Comparison of Rayleigh scatter due to Cirrus clouds and boundary layer aerosols

## 6 The effect of looking through a laser beam

This section describes the effect of one telescope looking through a laser beam projected by another telescope.

### 6.1 Effect at the pupil plane

If we are only concerned about the effect of Rayleigh scatter from a laser beam from another telescope on the (visible) WFSs (SH or pyramid); the pupil plane effect is important:

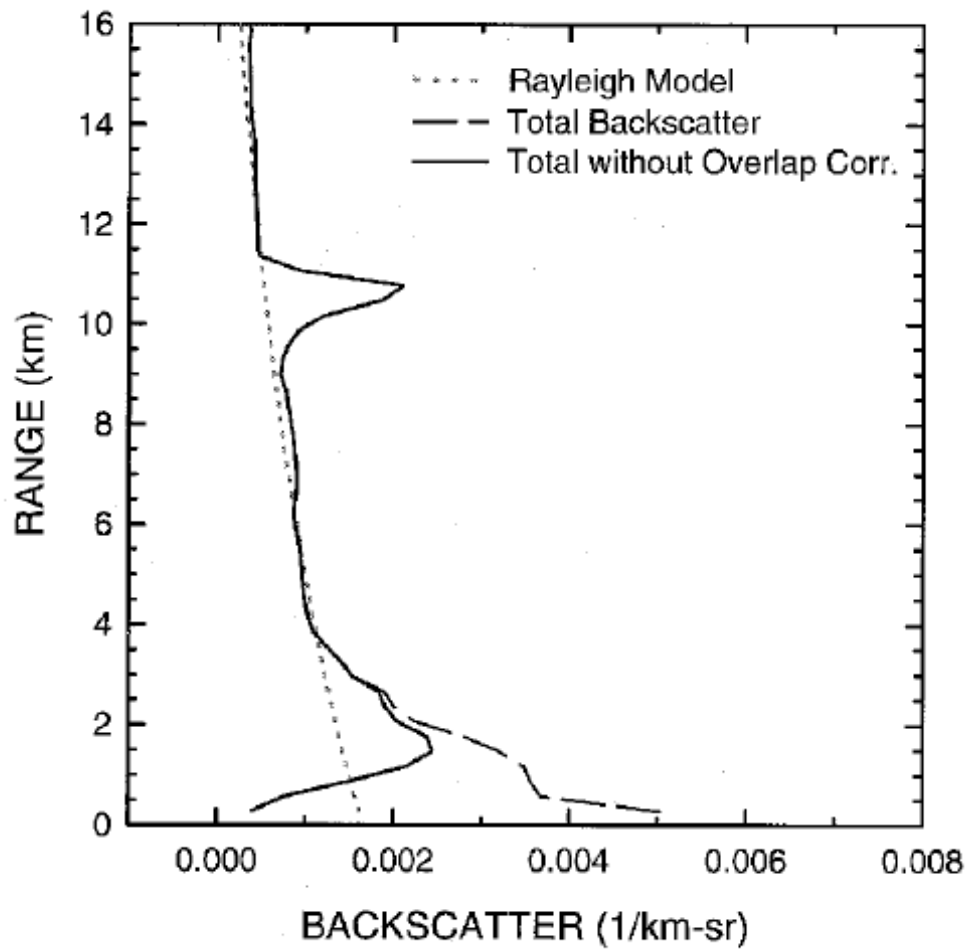

Figure 5: Comparison between modeled Rayleigh scatter and measured scatter in presence of sub-visual cirrus and boundary layer aerosols [3]

Mauna Loa Observatory  
NOAA/CMDL  
Hilo, HI  
Contact: J. E. Barnes

### Mauna Loa Ruby Lidar Aerosol Backscatter (15.8-33 km)

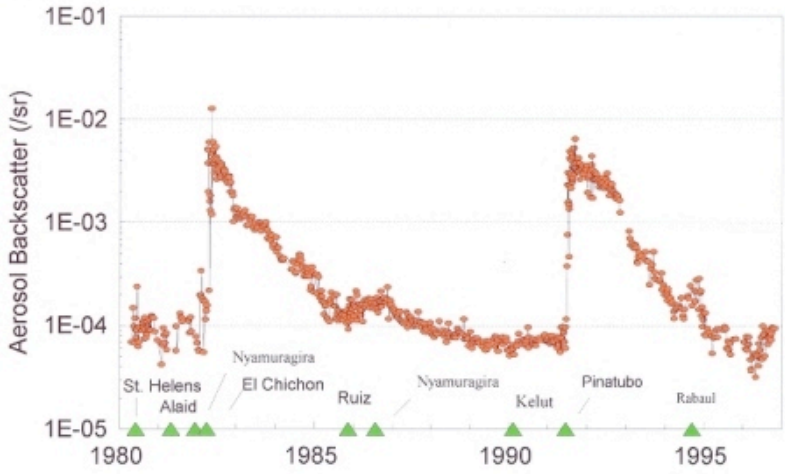

Figure 6: Long term trends (effect of volcanic activity of the aerosol scatter) [4]

The flux is concentrated in a rectangle of size  $(d+L \theta)(f/f) \times D(f/f)$  The total flux is given by:

$$N_{ph}(\phi) \pi \frac{d^2}{s} \frac{D}{\sin(\phi)} \frac{\pi(\theta/2)^2}{4\pi}$$

Where, d - distance to the laser beam from the receiving telescope

$\theta$  - is the FoV of the WFS

$N_{ph}$  - number of scattered photons towards the receiver (using dipolar scattering model for Rayleigh and Mie scattering models).

$\phi$  - angle between the optical axis of receiver and the laser beam.

D - diameter of the receiver

d - Diameter of the laser beam at point of intersection.

## 6.2 Effect at the focal plane

At the focal plane a ellipse with major and minor axes given by  $\frac{D}{L}$  and  $\frac{(D+d)}{L}$  [radians] is formed. The flux is the same as given above except for losses in the reflective/ transmissive surfaces between the pupil plane and the focal plane.

## 6.3 Yutaka et. al's conclusion

1. Rayleigh contamination from laser beams being launched from other observatories on Mauna Kea is comparable to the sky background. The skybackground scales as the D2 while Rayleigh effect scales at D.
2. The effect is of the order of 19.5 mv/(arcsec<sup>2</sup>) (while sky background is about 20.4 mv/(arcsec<sup>2</sup>)).
3. Not a concern for most observations.
4. The contribution from Mie scatter is less than 1/10th of that from the Rayleigh scatter. This is probably due to low density of aerosols at the observatory location.

## 7 Multiple laser beacons and fratricide issue

Due to lack of time we couldn't scale the preliminary work done to simulate the Rayleigh scatter to Keck's geometry perfectly yet. But one can derive useful insights from previous work done by Don Gavel and Brent Ellerbroek for the Gemini MCAO system. The Gemini MCAO system also has a quincunx LGS beacon geometry with center projection, but, the collector is 8 m in diameter with a different central obscuration and the spider geometry is different as well. The effect of Rayleigh scatter on different wavefront sensors for the projection geometry shown in 7 is depicted in 8. The figure 8 is of course simulated assuming a very large FoV for the sub-aperture as this gives one an idea of what the sub-aperture exactly sees in terms of both the Rayleigh and the resonant back scatter from the Na-layer. The bottom right figure shows a 20" window of what the sub-ap. sees. Figure 9 shows the distribution of the Rayleigh scatter on top of the Na back scatter and its distribution on a pixelated detector with 1 arcsec/pixel plate scale. This can be used to deduce SNR for different sub-apertures once the model is scaled properly in the detailed study phase of the project.

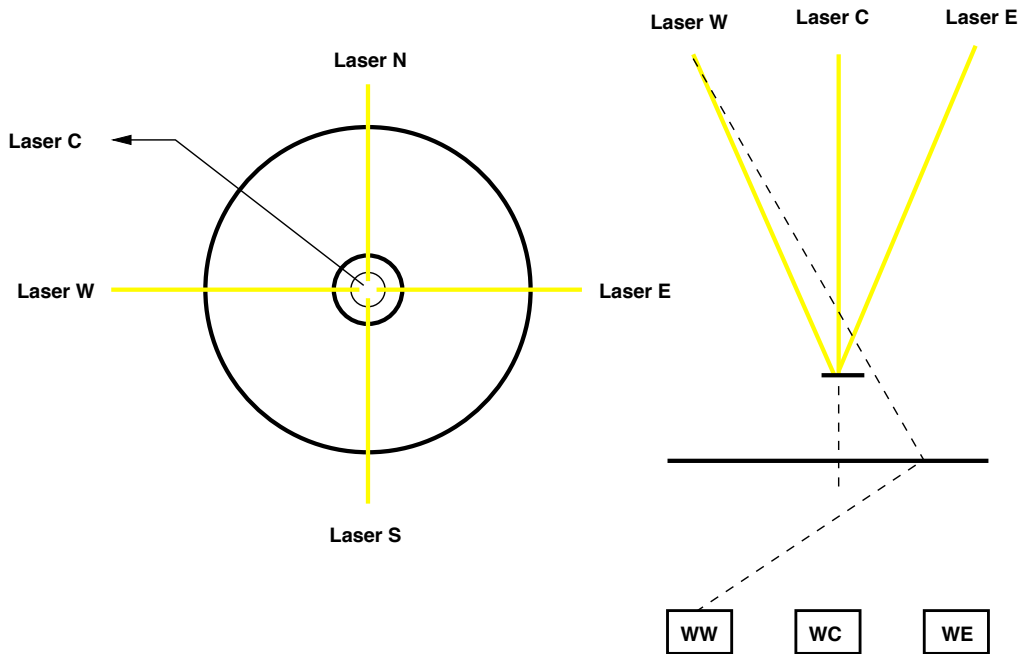

Figure 7: Projection geometry for fratricide analysis

## 7.1 Gavel and Ellerbroek's results

Different set of sub-apertures are affected in different WFSs. There is an SNR reduction by a factor of 2 in the worst affected sub-apertures for the Gemini case. The results from the Gemini MCAO system simulations done by Gavel and Ellerbroek are shown in 11 and 10 respectively. The distribution of Rayleigh scatter in center and corner wavefront sensors can be visualized from these.

## 8 Concluding remarks

Fratricide due to Rayleigh scatter is a serious issue for 5 laser beacon AO system. It is ideal to use a 1-3 micro-sec pulsed laser. In the eventuality of this not being available, (mode-locked) CW laser being the only option, appropriate background subtraction, projection location, baffles and stops are to be chosen. The effect of fratricide still needs to be quantified more accurately via. more detailed simulations, though, this work has developed a preliminary model for the same. It is advised that NGAO center project the beacons. A factor of safety ( some safety margin) must be included in the error budget to account for the short and long term fluctuations in Rayleigh scatter. Observing through the laser beam of another telescope doesn't actually render the data collected by a visible wavelength instrument totally useless as the effect is comparable to the sky background in the V-band.

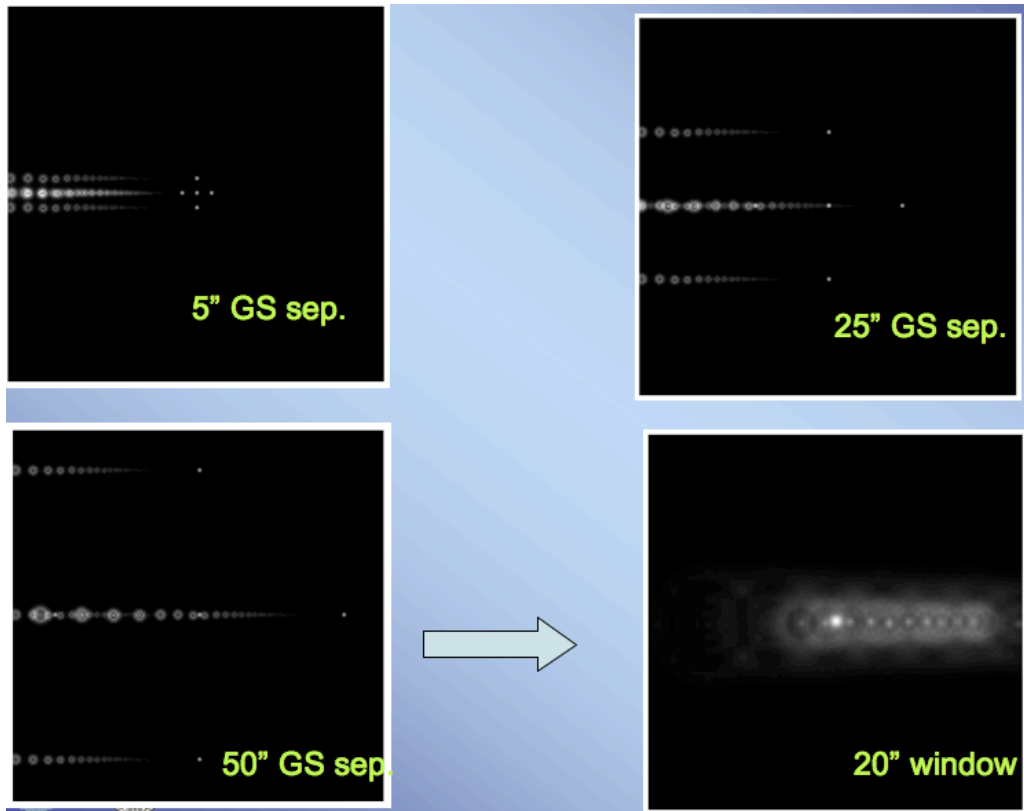

Figure 8: Preliminary simulation of the effect of 4 beacons as seen by a sub-aperture

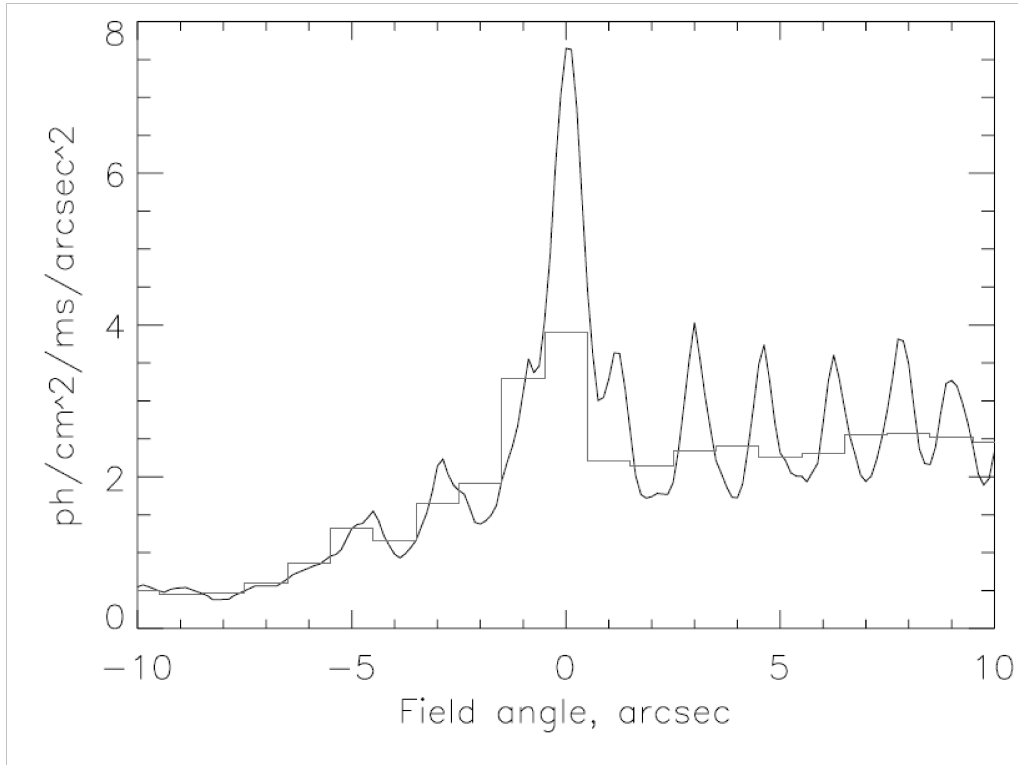

Figure 9: Sub-aperture flux

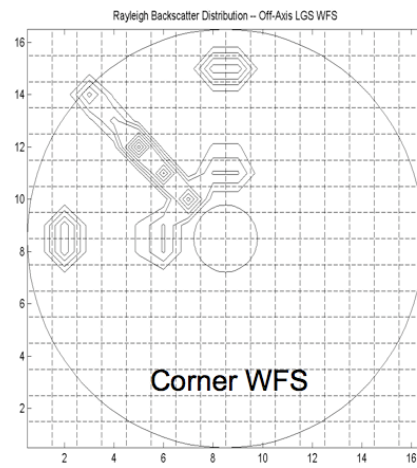
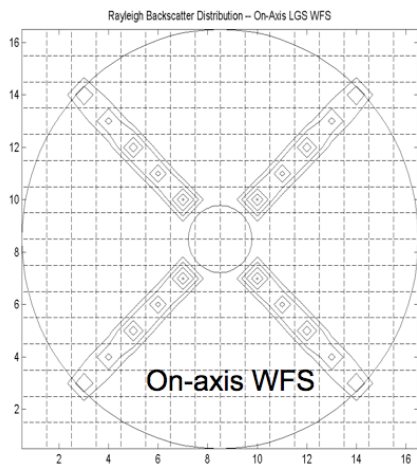

Figure 10: Results from Ellerbroek's simulation for the Gemini MCAO system



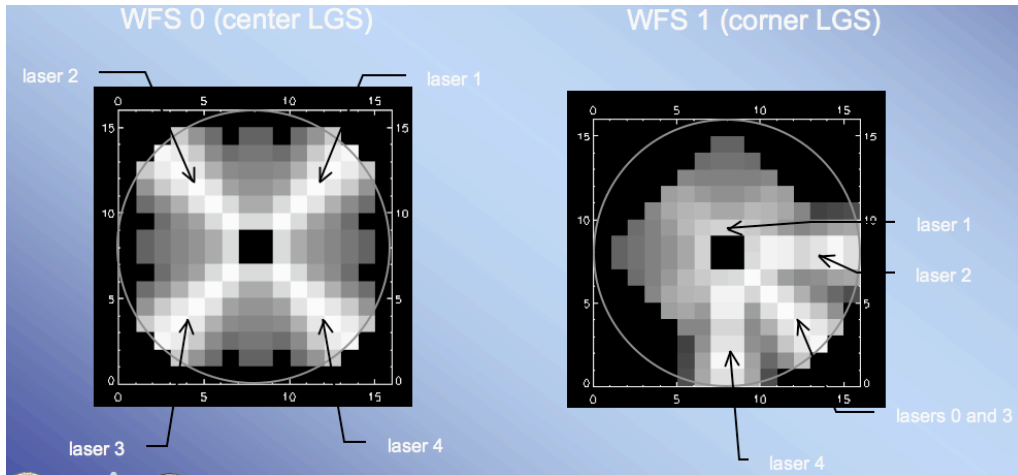

Figure 11: Results from Gavel's simulation for Gemini MCAO system

## References

- [1] Gardner, C.S., Proceedings of IEEE, 77, 408 (1989)
- [2] Hayano et. al., PASP 115, 1419-1428, 2003 Dec.
- [3] Cloud and Aerosol Height Distribution Retrieval and Analysis Employing Continuous Operation Lidar Data, J.D. Spinhirne et. al., Proceedings of the Seventh Atmospheric Radiation Measurement (ARM) Science Team Meeting, ARM-CONF-1997, March 1997, San Antonio, Texas
- [4] <http://www.mlo.noaa.gov/Projects/AEROSOL/Lidar.htm>
- [5] Gemini south MCAO presentation - Donald Gavel
- [6] Gemini south MCAO results - Brent Ellerbroek