



KAON # 759

Next Generation Adaptive Optics System

System Facility Electrical Power and Cooling Preliminary Design

May 12, 2010

Version V1.1

Prepared By J. Chin, C. Nance, C. Reed, E. Wetherell

REVISION HISTORY

Revision	Date	Author (s)	Reason for revision / remarks
1.0	March 01, 2010	All	Initial release
1.1	May 12, 2010	Nance	Preliminary Design Release

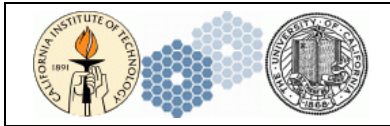

TABLE OF CONTENTS

REVISION HISTORY 2

TABLE OF CONTENTS 3

1 INTRODUCTION..... 4

2 REFERENCES..... 5

 2.1 REFERENCED DOCUMENTS..... 5

 2.2 ACRONYMS AND ABBREVIATIONS..... 5

3 OVERVIEW..... 6

4 POWER 7

 4.1 DETAILED DISCUSSION OF NGAO ELECTRICAL POWER LOADS **ERROR! BOOKMARK NOT DEFINED.**

 4.1.1 *Computer Room Electronics*..... 7

 4.1.2 *AO Bench Chiller*..... 7

 4.1.3 *Electronics Vault Power*..... 8

 4.1.4 *Electronics Vault Cooling System*..... 8

 4.1.5 *Laser Heat Exchanger (Reidel)*..... 8

 4.1.6 *“Davinci” First Light Instrument*..... 8

 4.1.7 *AO Cleanroom Cooling, Lighting, Convenience Power, and HEPA Filtration* 9

 4.1.8 *Summary of NGAO Electrical Power Loads* 9

 4.2 POWER AVAILABLE UPON RETIREMENT OF THE KECK II LGSAO SYSTEM 11

 4.3 ELECTRICAL POWER DESIGN FACTORS FOR NGAO..... 12

 4.3.1 *Design for Potential Increases in Power Consumption*..... 12

 4.3.2 *Design for Sufficient UPS Power*..... 12

5 HEAT REMOVAL FOR NGAO 13

 5.1 KECK II COMPUTER ROOM..... 13

 5.2 KECK II INSTRUMENT GLYCOL 14

 5.2.1 *Keck II Instrument Glycol Flow Capacity* 15

 5.2.2 *Keck II Instrument Glycol Cooling Capacity*..... 16

 5.3 KECK II MAIN CHILLER 16

 5.4 KECK II MECHANICAL ROOM..... 20

 5.5 KECK II BUILDING GLYCOL 20

6 CONCLUSIONS 21

7 APPENDIX B. KECK 2 ELECTRICAL ONE-LINE DIAGRAM..... 22

1 INTRODUCTION

The Next Generation Adaptive Optics System (NGAO) will require significant electrical power and cooling to operate it on the Keck II telescope. The power is needed to support the three lasers, an AO system, instruments, and auxiliary equipment. This power will come primarily from Uninterruptable Power Supplies (UPS) in order for the systems to ride through short power outages and other commercial power quality events common to Mauna Kea. Much of this power manifests itself in heat that must be removed by existing cooling systems.

This document examines the expected power and cooling requirements of the NGAO system and answers the following five questions:

- Does the Observatory have sufficient power for NGAO, assuming LGSAO is retired?
- Is the delivery of power to NGAO a concern to the success of the project?
- Is there any major, new infrastructure required to power NGAO?
- Is there sufficient cooling infrastructure to remove the heat generated by NGAO?
- Is there any major, new infrastructure required to remove heat from NGAO?

The conclusion from answering these questions suggests that NGAO power and cooling requirements are not major risk to the success of the project. It will be shown that some new infrastructure will be necessary, but that work is straightforward.

2 REFERENCES

2.1 Referenced Documents

Documents referenced are listed in Table 1. Copies of these documents may be obtained from the source listed in the table.

Ref. #	Document #	Revision or Effective Date	Source	Title
1	KAON 511	0.3	WMKO	NGAO System Design Manual
2			WMKO	W.M. Keck Observatory Phase II Equipment Schedule, Daly Drawing M2.19
3			WMKO	“Introduction and Function of the Cooling Unit” by Danfoss/Kyl, archived in the W.M. Keck Observatory library.

Table 1: Reference Document

2.2 Acronyms and Abbreviations

Table 2 defines the acronyms and abbreviations used in this document.

Acronym/Abbreviation	Definition
AO	Adaptive Optics
CCR	Closed Cycle Refrigeration
HBS	Hydrostatic Bearing System
KAON	Keck Adaptive Optics Note
LGS	Laser Guide Star
LGSAO	Laser Guide Star Adaptive Optics System, existing on Keck II
NEC	National Electrical Code
NGAO	Next Generation Adaptive Optics System
OSIRIS	Near-Infrared Integral Field Spectrograph, existing on Keck II
UPS	Uninterruptable Power Supply
WMKO	W.M. Keck Observatory

Table 2: Acronyms and Abbreviations

3 OVERVIEW

The entire NGAO system is shown in Figure 1. A significant portion of the system will be located on the telescope, in the AO clean room, and in the AO electronics vault, while the remaining equipment will be located in the computer room.

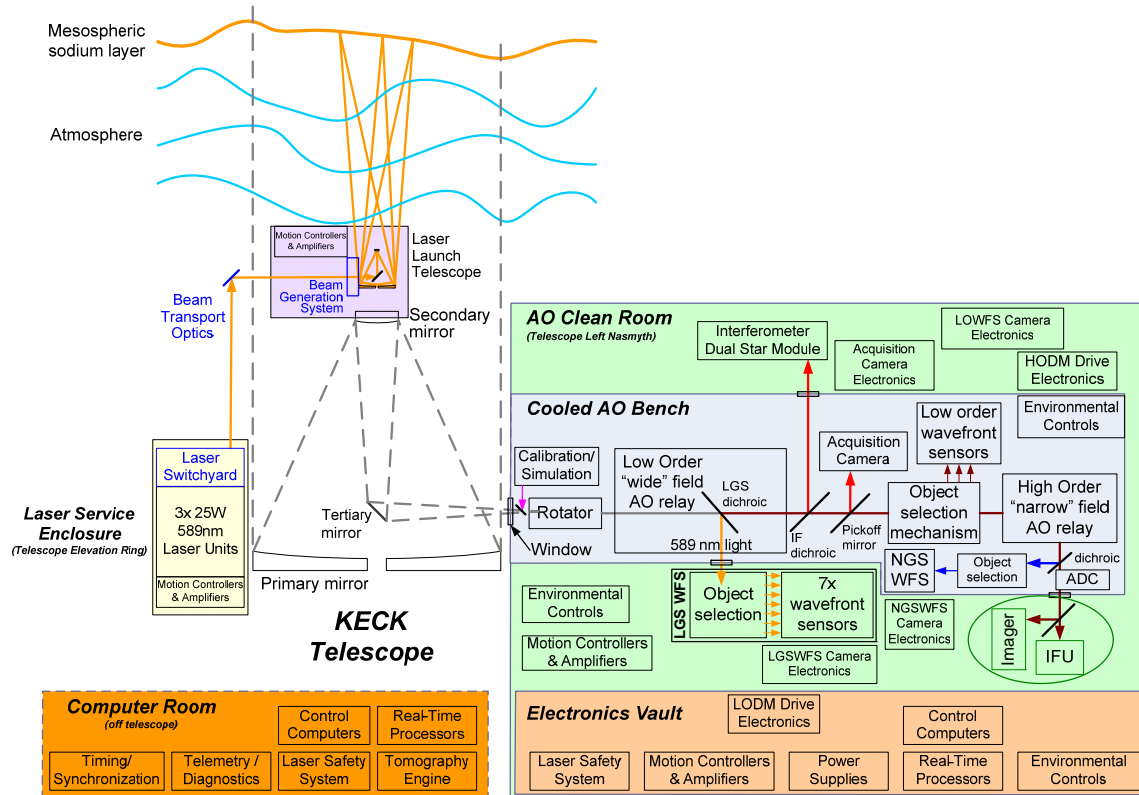

Figure 1: NGAO System

4 POWER

In this section the electrical power requirements for various NGAO electrical loads are discussed in detail. They are summarized in Table 3. Appendix A is the one-line electrical diagram for Keck II. This can be used to visualize proposed sources for NGAO power.

4.1.1 Computer Room Electronics

Approximately half of the NGAO electrical power will be consumed by a large collection of electronics and computer hardware which will be located in the Keck II Computer Room. This hardware includes the real-time processors, tomography engine, timing/synchronization, control computers, and associated hardware. This equipment will be installed in standard 19" racks. This is shown schematically in Figure 1, highlighted in deep orange.

It is estimated that this hardware will consume 20.9kW of electrical power fed by a 3-phase 208 VAC service. It is likely that a single 208VAC electrical panel will be installed in the Keck II Computer Room to feed these new racks of hardware.

It is necessary for this hardware to be backed by UPS power. Due to space limitations it is likely that the UPS will be physically located in the Keck II Mechanical Room, adjacent to an existing 40kW UPS system that feeds existing Keck II instruments and the Keck Interferometer. This new NGAO UPS will require a large transformer in advance of it to convert 480VAC power to 208VAC. Keck has several large, unused transformers that can be allocated for this service. It is likely the power will be drawn from a 480VAC electrical panel MSB2. This panel is not on the generator, so the UPS will require sufficient excess battery capacity to provide a reasonable runtime during power outages. The primary reason for the UPS is to improve the power quality and provide ride-through of short outages (<5 minutes). In the event of an extended outage, the NGAO computer room hardware will lose power.

It is important that the computer room electronics power have an over-temperature shutoff as part of the design, such as a thermostat tied to a shunt trip circuit breaker on the power feed. Since the NGAO computer room electronics power will be on a UPS, but the computer room air conditioner is not, there is a scenario where the room can catastrophically overheat. Simple shunt-trip based protection is commonly used at Keck to protect the existing AO vaults, as well as the main computer rooms.

4.1.2 AO Bench Chiller

At the core of NGAO is the Cooled AO Bench. This area is depicted in Figure 1 with light blue shading. This area is similar to a Dewar, being cooled to -15°C air temperature. Owing to the natural inefficiencies of heat transfer, it is necessary that the glycol used to cool that air to -15°C be as cold as about -30°C.

The -30°C glycol will be provided by a dedicated chiller under the Nasmyth platform relatively close to the Cooled AO Bench. This chiller will be referred to as the *AO Bench Chiller*.

The AO Bench chiller will be powered by 208VAC, 3-phase, 1kW power. It is not necessary for this chiller to be on UPS power. This chiller will be powered from a commercial power source that is also on the generator, likely panel ERP-10. For extended power outages, the generator will provide power to this chiller.

The AO Bench Chiller will require ~1kW of instrument glycol for its condenser cooling.

4.1.3 Electronics Vault Power

The AO Electronics Vault power is used to provide primary power for the lasers, motion control, and other functions. This area is shown in Figure 1, “Electronics Vault”, highlighted in light orange.

The electronics vault will consume 11.5kW of electrical power at 208VAC, 3 phase. It is necessary for this power to be UPS backed, likely from the same NGAO UPS described in §4.1.1.

It is important that the electronics vault power have an over-temperature shutoff as part of the design, such as a thermostat tied to a shunt trip circuit breaker on the power feed. Since the electronics vault power is on a UPS, but the cooling system for the room is not, there is a scenario where the room can catastrophically overheat. Simple shunt-trip based protection is commonly used at Keck to protect the existing AO vaults, as well as the main computer rooms.

4.1.4 Electronics Vault Cooling System

The AO electronics vault (§4.1.3) will have an estimated 11.5kW of heat dissipated into it. It is a highly insulated enclosure, so practically all of that heat must be removed with instrument glycol cooling. It is expected that the electronics vault cooling system will be identical to the existing LGSAO electronics vault cooling system. This would be a fan/coil unit that would use instrument glycol as the heat removal medium. It is expected the fan/coil unit will consume 0.67kW of electrical power at 208VAC, 3-phase. It is not necessary that this power be on a UPS. Since instrument cooling is not on a generator, there is no value in providing more than common commercial power.

4.1.5 Laser Heat Exchanger (Reidel)

NGAO will consist of three separate, identical laser systems. These laser systems require 18C glycol for cooling. This is much higher temperature than is provided by existing glycol systems within the Keck facility.

This 18C glycol service will be provided by a Reidel WTS 008-05-NES packaged heat exchanger unit, located under the Nasmyth platform relatively close to the electronics vault.

Instrument glycol will provide the primary cooling for the heat exchanger. Its output side will be modulated to provide the 18C for the lasers electronics and laser units. Some 18C glycol goes into laser hardware located in the electronics vault. A smaller quantity of glycol is piped to the elevation ring to laser service enclosure. It is necessary that all 18C lines be sufficiently insulated to minimize heat dissipation into the ~0C dome environment.

The Reidel heat exchanger will be powered by 480 VAC, 3-phase, 1kW power. It is unprecedented for Keck, but permitted by NEC, to route 480VAC onto the telescope. In the DDR phase the NGAO team will determine whether it is possible to obtain the heat exchanger packaged as a 208VAC device. It is not necessary for this heat exchanger to be on UPS power. This heat exchanger will be powered from a commercial power source that is also on the generator, likely panel EDP-3. For extended power outages, the generator will provide power to this heat exchanger.

The Reidel heat exchanger will remove 4kW of heat from the laser system. As a result, it is expected that the Reidel heat exchanger will reject 5kW of heat into instrument glycol.

4.1.6 “Davinci” First Light Instrument

NGAO’s first light instrument is Davinci. It will require electrical services nearly identical to existing CCR instruments, such as OSIRIS. Davinci is located in the AO clean room adjacent to the cold bench.

Davinci will require 1kW of electrical power. It will require instrument cooling, and will inject an identical 1kW into instrument cooling.

Since Davinci is a CCR instrument, it will have a helium compressor in the Keck II mechanical room. This compressor will require 5kW of 480VAC, 3 phase power. Since the OSIRIS instrument is being moved to Keck I, power and cooling infrastructure is freed for the Davinci helium compressor.

In summary, Davinci is not materially different than existing instruments from a power and cooling standpoint. Thus, providing power and cooling for Davinci will be simple and straightforward.

4.1.7 AO Cleanroom Cooling, Lighting, Convenience Power, and HEPA Filtration

NGAO will have a cleanroom, which is shown in Figure 1 highlighted in green. This environment will require a cooling system to remove heat, personnel lighting, convenience outlets for tools, and must be HEPA filtered to maintain acceptable levels of dust.

4.1.8 Summary of NGAO Electrical Power Loads

Below is a table that summarizes all of the NGAO electrical power loads. Each of these loads were discussed in §4.1.1 through §4.1.7. NGAO will require an estimated baseline of 41kW of electrical power.

History suggests that the actual power consumed by a new system will vary significantly from the design. And, future improvements to an operational system inevitably require more electrical power versus the initial capability. Thus, as a general rule of thumb, power systems should be designed and built to carry at least 50% more power versus the initial capacity. It is recommended this rule of thumb be applied to NGAO. In Table 3, there is a column that calculates this 50% margin. This significantly reduces the risk associated with additional infrastructure to support any future needs for the NGAO system.

<u>Name</u>	<u>Location</u>	<u>Proposed Source</u>	<u>Power (kW)</u>	<u>Power w/50% Margin</u>	<u>Cooling</u>	<u>Description</u>
Computer Room Electronics	Keck II Computer Room	MSB2 + TRL or TR3 + NGAO UPS	20.9	31.4	Keck II Computer Room AC	Electronics and computer infrastructure for NGAO, such as RTC
NGAO Instrument CCR Compressor	Keck II Mechanical Room	ECCR2	5.5	8.25	Keck II Building Glycol	CCR Compressor for NGAO Instrument "Davinci"
UPS Dissipation	Keck II Mechanical Room	NGAO UPS	4	6	Keck II Mechanical Rm Ambient Air	Heat dissipation (loss) from NGAO UPS
NGAO Electronics Racks Power	Keck II Left Nasmyth Platform	NGAO UPS	15.3	22.9	Keck II Instrument Glycol	This is the electronics vault on the Keck II telescope. This includes the NGAO laser systems.
Cooling System for NGAO Electronics Vault	Keck II Left Nasmyth Platform	ERP-10	0.67	1.0	Keck II Instrument Glycol	Cooled similar to existing Keck II AO electronics vault; fan/coil unit w/0.5Hp fan
Main AO room for NGAO	Keck II Left Nasmyth Platform	NGAO UPS	4	6	Keck II Instrument Glycol	This is the bench area for NGAO. It must be cooled to a temperature TBD. This includes all electronics near the AOB
Chiller for NGAO Cold Bench/Cold Box	Within NGAO Clean Room Area, on Keck II Left Nasmyth Platform	ERP-10 or NGAO UPS	1	1.5	Low temperature glycol chiller	Air cooled to -15C by -30C glycol
NGAO Laser Service Enclosure Cooling	Keck II Elevation Ring	CLP2	1.4	2.1	Keck II Instrument Glycol	Laser enclosure that needs to be cooled in a similar fashion as the Keck I laser.
Beam Generation System	Keck II Secondary	ELR2 or NGAO UPS	0.1	0.15	Needs to be cooled by instrument cooling	Small electronics package on Keck II secondary cooled with instrument glycol
Keck II NGAO Laser Heat Exchanger	Suspended beneath Keck II Left Nasmyth Platform	EDP-3	1	1.5	Heat exchanger cooled with Keck II Instrument Glycol	Reidel WTS 008-05-NES. Note powered by 480VAC, 3ph.
Cryo Tigers	Suspended beneath Keck II Left Nasmyth Platform	NGAO UPS	1.5	2.25	Keck II Instrument Cooling	CCR for WFS cameras
		TOTAL =	55.4	83.0		

Table 3: NGAO Electrical Power Requirements

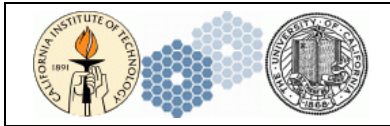

4.2 Power Available Upon Retirement of the Keck II LGSAO System

It is understood that the Keck II LGSAO system will be retired as a necessary precondition for the installation of NGAO. Most, if not all, of the power for NGAO will come from the retirement of Keck II LGSAO.

In March 2010 a study was conducted to determine the actual operational power consumption of Keck II LGSAO. The study used a Hioki power monitor, handheld amp meters, and estimates by supervising electricians. The study found 97kW of electrical consumption by Keck II LGSAO. The results are summarized in the table immediately following:

Item	Circuit	Power (kW)	Meter	Date	Notes
Keck II Laser Room	MSB-2, Ckts 7,9,11 TR-L	54	Hioki	2/26/2010	Large laser room on Keck II dome floor.
Keck II Laser Table Enclosure UPS Power	ELRC-2, Ckts 20,22	1	Estimated	-	Laser enclosure on Keck II elevation ring; 2 ea 20A circuits.
Keck II Laser Table Enclosure Lighting/Gen'l Use	ELR-2, Ckt 22	0.5	Estimated	-	One lighting and general use outlets circuit
Keck II Supplemental Chiller	MSB-2, Ckts 19,21,23 "Keck II Mech Room Welding Outlet"	26.13	Hioki	3/2/2010	Located in Keck II Mechanical Room. GCI Refrigeration 220ACLT having a capacity of 87,000 BTU/hr (7.25 Ton) at 0F.
Keck II Glycol Cooler Laser Load	MCC-5	3.42	Hioki		Additional electrical consumption by GC2 operating more during Keck II LGS-AO operations
Keck II AO Electronics Vault UPS Power	AO NPC-2	5	Handheld	2/26/2010	On Keck II Telescope
Keck II AO Electronics Vault Commercial Power	AO NP-2	5	Handheld	2/26/2010	On Keck II Telescope
OSIRIS Computer	EDP4, Ckts 2,4,6	1	Estimated	-	In Keck II Computer Room
OSIRIS Guider Computer	TBD	1	Estimated	-	Keck II computer room (verify)
	TOTAL =	97			

Table 4: Power Available from Retiring the Keck 2 LGSAO System

4.3 Electrical Power Design Factors for NGAO

Based on the analysis concluded in the PDR phase, it is clear that NGAO will consume significantly less electrical power than the existing LGSAO system. The present LGSAO system consumes an estimated 97kW of electrical power. NGAO is estimated to consume 41kW. With allowances for an increase in NGAO power consumption by +50%, NGAO will still consume less electrical power than LGSAO

For the Detailed Design Phase, several factors should be adopted as central elements in the detailed design.

4.3.1 Design for Potential Increases in Power Consumption

Keck experience suggests that the actual power consumed by a new system will vary significantly from the design. And, future improvements to an operational system inevitably require more electrical power versus the initial capability. Thus, as a general rule of thumb, power systems should be designed and built to carry at least 50% more power versus the initial capacity. It is recommended this rule of thumb be applied to NGAO. In Table 4 there is a column that calculates this 50% margin. This significantly reduces the risk associated with additional infrastructure to support any future needs for the NGAO system.

4.3.2 Design for Sufficient UPS Power

Unlike the Keck II LGSAO system, NGAO will require significantly more UPS power than non-UPS power. To simplify the electrical design, it is recommended that all NGAO power be from a single UPS unless there is clear and simple alternative power connection available for a particular load.

As mentioned previously, experience with past systems indicates that NGAO may draw more power than estimated, leading to the recommendation of a +50% power margin. Additionally, NGAO's UPS must have sufficient margin to bridge power outages of moderate duration, and sufficient internal redundancy. Thus, it is likely that two 40KW UPS'es are required.

Keck presently has four APC Symmetra PX 40kW UPS'es in-service at the summit. They have proven to be reliable and effective at providing exceptionally good power quality. Symmetra PX 40kW units are scalable to 80kW, allowing for any unexpected increases in power consumption. During the detail design phase it will be decided whether all of NGAO be fed from a single UPS, or the NGAO Computer Room load be split from the remainder of the NGAO loads, and each being fed by a 40kW UPS. A UPS system for NGAO is expected to cost approximately \$60K.

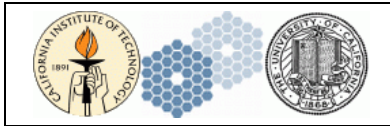

5 HEAT REMOVAL FOR NGAO

Section 4 estimated that NGAO will consume a nominal 41kW of electrical power, but possibly as much as 62kW. Virtually all of this power consumed by NGAO will ultimately manifest itself as heat, placing cooling demand on various air conditioners and glycol cooling systems. This section will discuss whether there is sufficient cooling for NGAO.

The heat removal requirements in some locations will be mitigated by the retirement of LGSAO; other locations not. Although it is possible to provide electrical power to a given location, it is important to ensure that the heat generated at these locations can be removed by the existing cooling infrastructure. Or if not, plan for improvements in cooling systems to remove NGAO heat.

5.1 Keck II Computer Room

As shown in Table 3 and discussed in §4.1.1, an estimated 20.9kW, which is about half of the total NGAO heat load, will be rejected into the Keck II Computer Room. The Keck II Computer Room is an air conditioned environment maintained at approximately 61°F. This cooling is accomplished by the Keck II Computer Room AC unit, AC-24. The Keck II Computer Room AC is a Data Aire DAGD-2034 having a cooling capacity of 189,800 BTU/hr (16 Ton or 55.8kW) (Ref 2). This AC unit is water cooled. Heat removed by AC-24 is put into the building glycol system. Ultimately this heat adds additional load to the building glycol cooler GC-2, as will be discussed in section 5.3 of this document. Later it will be shown there is sufficient building glycol cooling for AC-24. The question is only whether AC-24 can remove the heat added to the room by NGAO.

NGAO proposes to add 20.9kW of additional heat load to the Keck II Computer Room. NGAO does not plan to remove any existing significant loads from the Keck II Computer Room to offset this added heat above the present. To ensure a +50% margin, it is assumed that 31.4kW of heat will be added to the Keck II Computer Room by NGAO.

A survey was conducted in the Keck II Computer room. It was determined that 14.8 kW of electrical load is consumed in the room at the present time. This heat is tabulated below:

Name	Circuit	Power (kW)	Meter	Date Measured	Description
Keck II Computer Room UPS	MSB2, AC-24	13.4	Handheld Meter, UPS data	2/25/2010	Keck II Computer Room UPS. All of this power feeds panel URP-2. These loads are ACS, DEIMOS, OSIRIS, NGWFC, and more.
Keck II Computer Room Outlets	ERP-6A	0.7	Handheld	2/25/2010	Lightly loaded outlets under the computer room floor.
Keck II Computer Room Outlets	ERP-6B	0.7	Handheld	2/25/2010	Lightly loaded outlets under the computer room floor.
SAA	EDP4, CKT 2,4,6	1.5	Hioki	3/9-3/12 2010	Power for SAA
Fluorescent Lighting	Various	2	-	estimate	Power draw when all fluorescent lighting is on.
	Total Req =	18.3			

Table 5: Current heat load in computer room

Power monitoring equipment was installed onto AC-24. The total power consumed by the AC unit is shown in the graph below:

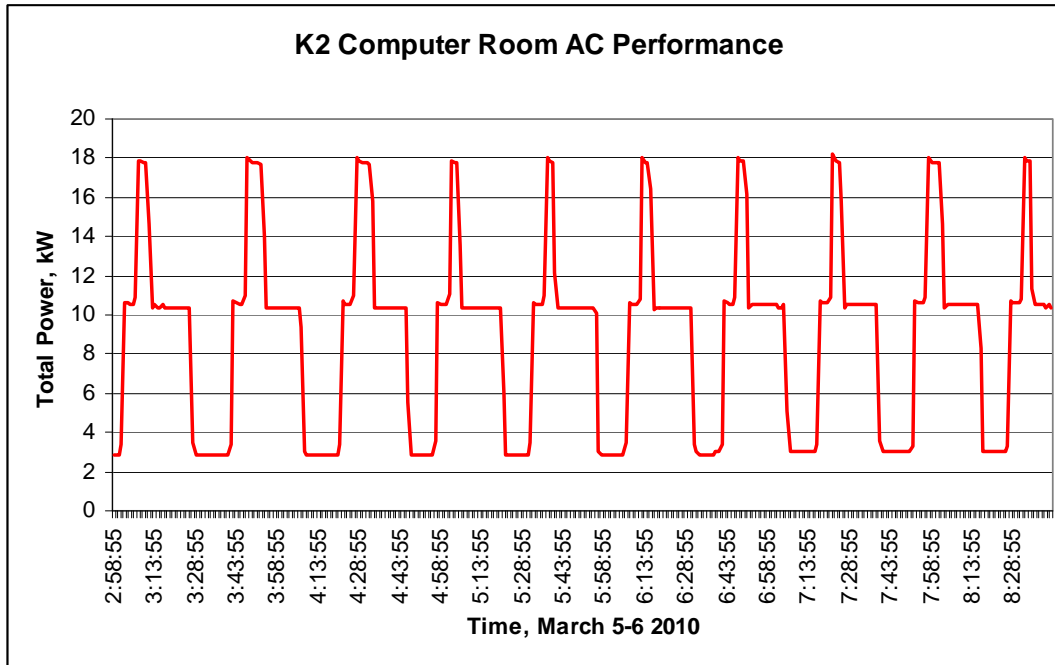

Figure 2: Keck II computer room AC performance

Notice that there is a baseline power consumption of 2.9kW. This power is primarily the circulation fan for the AC unit. Then, notice that the AC has two stages of cooling. Each stage is 7.5kW.

Analysis of this actual performance data concludes that AC-24 is operating at 40.8% of capacity. If the maximum cooling capacity is truly 55.8kW, then the AC is removing 22.8kW. This agrees reasonably with the identification of 18.3kW of heat loads in the computer room.

It is thus concluded that AC-24 has sufficient capacity to cool the Keck II Computer Room if an additional 20.9 kW of heat is added by NGAO. In the event NGAO consumes 31.2kW, the AC unit will still have sufficient capacity, but in that case will be operating near its performance maximum.

5.2 Keck II Instrument Glycol

NGAO will add cooling loads to the instrument cooling system for the Keck II telescope. It is important to understand the designed performance of this system, and then understand how NGAO might affect its performance. There are two major performance considerations for determining whether the existing Keck II instrument glycol system can support NGAO:

1. Whether there is sufficient pumping capacity to support the additional flow demands.
2. Whether there is sufficient cooling capacity can provide sufficiently cold glycol at that flow. Refer to Figure 3 for the discussion to follow:

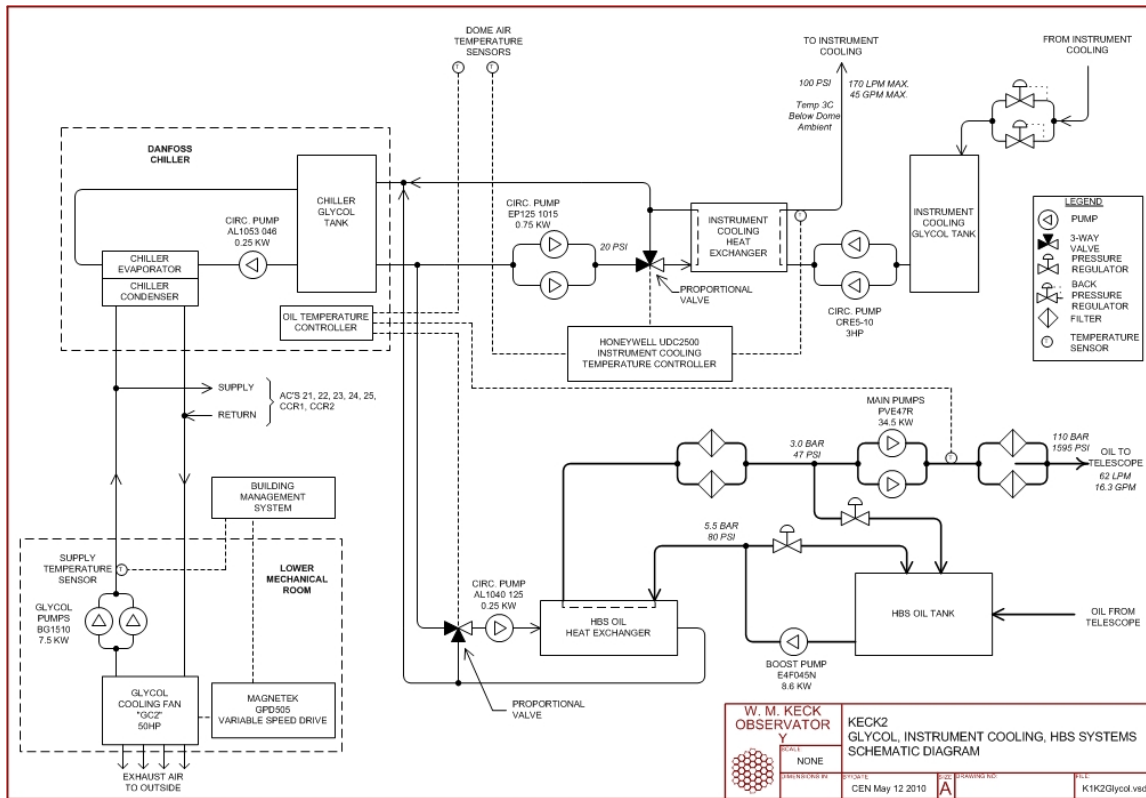

Figure 3: Existing Keck II Cooling Systems

5.2.1 Keck II Instrument Glycol Flow Capacity

The Keck II Instrument Glycol System flow is driven by a pair of Grundfoss CRE5-10 pumps. Each pump has a flow capacity of 45GPM. From an operational standpoint the total instrument glycol flow must not exceed 45GPM. When flow exceeds 45GPM both instrument glycol pumps must run simultaneously, which leaves no failure redundancy and does not allow a pump to be off line for service or repairs. The present instrument glycol flow demand is ~30GPM. Since most of that 30GPM is related to LGS AO, it is expected that the instrument glycol flow demand of NGAO will be similar to LGS AO. In the highly unlikely event that NGAO tips the total system flow greater than 45GPM, modifications to the pump system will be required such as installation of a third pump module.

As flow increases the diameter of the piping becomes a greater concern since flow resistance increases with velocity. In the detailed design phase it will be necessary to inspect the instrument glycol piping and perform flow resistance calculations based on the greatest predicted flows. PDR-phase surveys suggest that the present piping is of sufficient diameter. In the event larger glycol piping is necessary, it would be a straightforward plumbing task. Any flow concerns might be mitigated by simply relocating the pressure sensor for the instrument glycol system from the pumps manifold to the instrument cooling piping on the telescope. This would allow for more pressure at the pumps, yet maintain the proper pressure at NGAO and other system elements.

5.2.2 Keck II Instrument Glycol Cooling Capacity

The Keck II Instrument Glycol System is intended to provide glycol that is 3°C below the dome ambient air temperatures as measured on the dome floor. The typical range of coolant temperatures is -6°C to 0°C. A Honeywell temperature controller continually monitors the dome air temperature and adjusts the temperature of the instrument glycol accordingly. This control is required because the glycol piping is not insulated. It is not practical, nor is it necessary, to insulate these lines. If the glycol were warmer than the dome air temperature, the glycol lines would radiate unacceptable levels of heat into the dome, possibly affecting seeing. If the glycol were significantly cooler than the dome air temperature, the lines would become frosted and become coated with ice on occasion, which would later melt and risk harm to wiring and other equipment. For the purposes of NGAO, it is important to take into consideration that the instrument glycol temperature is variable.

Instrument glycol is cooled through the secondary side of the “Instrument Cooling Heat Exchanger”, as shown in Figure 3. The primary side of that heat exchanger is cooled from an -18°C glycol source “Chiller Glycol Tank.” This -18°C glycol is used to cool both instrument glycol and the HBS oil. The -18°C glycol is produced by the Danfoss Chiller. The Danfoss Chiller was provided by the hydraulics firm Hydraul/Syd as a deliverable for the HBS system. Its excess cooling capacity is used to provide Keck II instrument cooling.

Based on the sizing of the piping and the capacity of the EP125 circulation pumps, there are no modifications to the instrument cooling loop necessary. Note carefully that §5.3 will describe that the Danfoss Chiller does not have the capacity to provide -18C glycol with NGAO.

5.3 Keck II Main Chiller

The Keck II Main Chiller is a Danfoss Chiller manufactured for Hydraul/Syd as part of the Keck II Hydrostatic Bearing System. The primary function of the cooling unit is to chill a reservoir of glycol to approximately -18°C. Glycol in that reservoir is used to provide cooling for the HBS oil and instrument glycol. This is seen in Figure 3. The Keck II Main Chiller has a rated cooling capacity of 37.6kW (10 Ton) at -30°C (Ref 3).

Power consumption readings for the Keck II Main Chiller were taken during March 5-9, 2010. The chiller has a single stage of cooling, drawing 27kW when operating. Data showing a typical night of operations is immediately below:

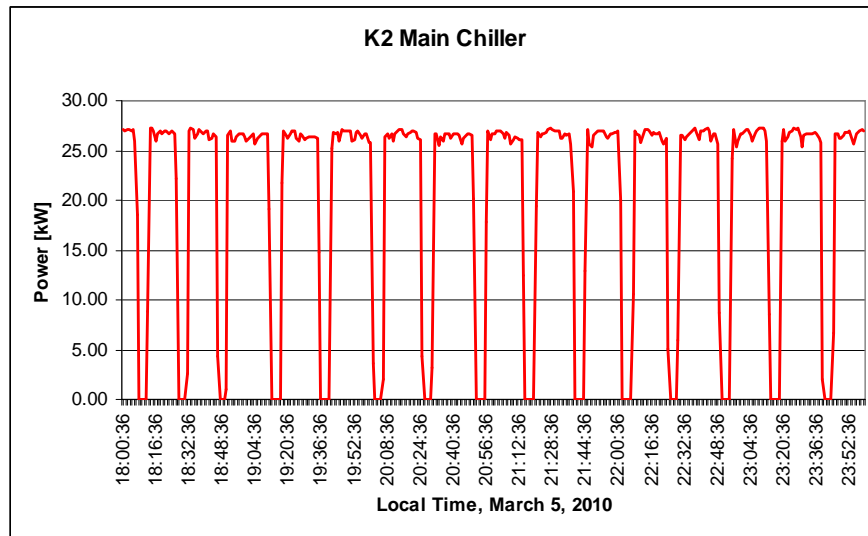

Figure 4: Keck II Main Chiller Usage

Analysis of the data indicates that the chiller is operating at 76% of maximum capacity at night-time. A casual glance at this data leads to the conclusion that the chiller is operating near its rated capacity at the present time.

The proposed NGAO instrument glycol loads are listed below. Some of the loads are offset by the retirement of the existing LGSAO:

Heat Load	Power (kW)	Offset by LGSAO Retirement?
NGAO Electronics Racks	11.3	Partially (all but 1.3kW)
Cooling System for NGAO Electronics Vault	0.67	Yes
Main AO Room Cooling for NGAO	4	No
Chiller for NGAO Cold Bench/Cold Box	1.0	No
NGAO Laser Service Enclosure Cooling	1.4	No
Beam Generation System	0.1	No
KII NGAO Laser Heat Exchanger	5.0	No
Cryo Tigers	1.5	No
Total	15	

Table 6: NGAO Instrument Cooling Requirements

These figures suggest that NGAO will add an additional 15 kW of heat load onto the main chiller, even accounting for loads that are retired by LGSAO. If we assume a +50% margin, then the additional heat load could be at great as 22.5 kW. Because of the present 76% duty cycle of the K2 main chiller, it is

expected these additional proposed NGAO heat loads will exceed the Keck II Main Chiller capacity margin. To ensure the success of NGAO, it is necessary to provide additional cooling capacity for Keck II instrument glycol.

Fortunately, a source of supplemental cooling is readily available to NGAO. The original Keck I main chiller was replaced in 2007. The new chiller has a cooling capacity that far exceeds all present and future loads for Keck I. At the time the chiller was specified, it was expected that the K1 Laser System would be a much greater heat load than it actually tuned out to be. And, the chiller manufacturer, ArctiChill, through a fortuitous manufacturing error, made the new K1 chiller with 50% greater capacity than what Keck purchased; ultimately at no additional cost to Keck. The outcome of this is that K1 has much greater chiller capacity than needed for any present or proposed K1 loads. This excess cooling capacity can be used to benefit NGAO. This can be implemented by installation of pumps and piping to interconnect the Keck I and Keck II glycol systems. An unused, extra ArctiChill chiller module, presently in storage, would be installed into the Keck I chiller. Pumps and piping would be installed to mix the glycol between the two separate glycol chiller tanks for Keck I and Keck II. This would require a pair of 3" copper lines between the Keck I and Keck II mechanical rooms. It is expected that the Keck I ArctiChill chiller has sufficient pumping capacity to pump glycol to the Keck II glycol chiller tank. The glycol is returned from Keck II back to Keck I by means of an unused Grundfoss pumping system that was originally intended for the Keck I laser. A conceptual sketch of this interconnection of the K1-K2 glycol systems is shown below:

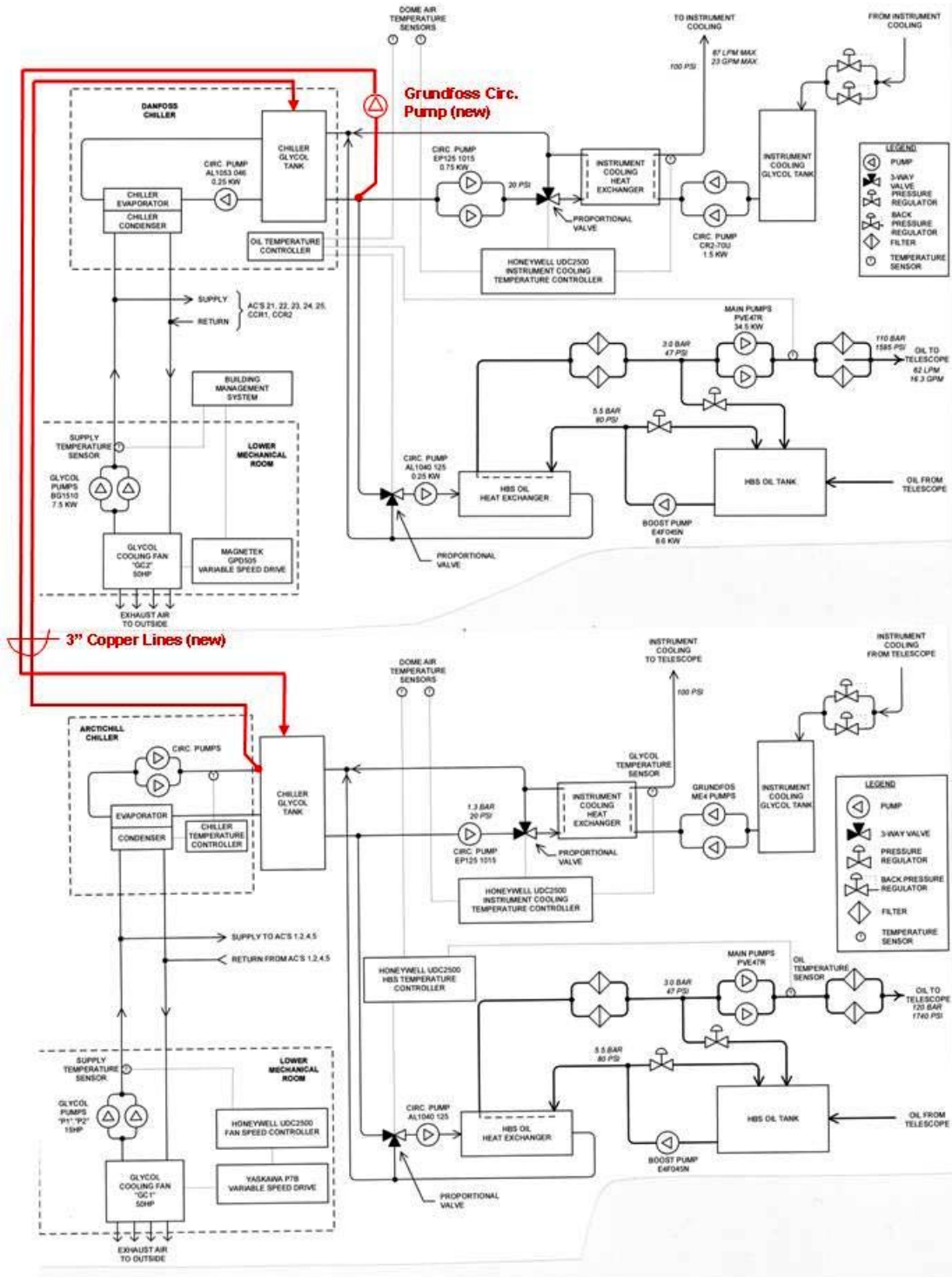

Figure 3: Proposal to Interconnect Keck I and Keck II Glycol Systems



5.4 Keck II Mechanical Room

The NGAO UPS is planned for installation in the Keck II mechanical room. At the present time the cooling for the Keck II mechanical room is marginal when the LGSAO is operating. This is due to the supplemental icewagon that is used to cool the Keck II laser, as its rejected heat is released into the Keck II mechanical room. At the present time the Keck II Instrument UPS routinely approaches over-temperature shutdown when LGSAO is operating. With the retirement of LGSAO and the elimination of the Keck II LGS icewagon, the heat load into the Keck II mechanical room will return to normal. In that case, there is more than sufficient cooling for the NGAO UPS to be installed in the Keck II mechanical room.

5.5 Keck II Building Glycol

The Keck II Building Glycol system is a closed loop cooling system. It is designed to remove heat from various liquid cooled equipments, such as the Keck II Computer Room AC (AC-24), the Keck II Main Chiller, and many other loads. As can be seen in the above sections, three items are affected by NGAO: Keck II Computer Room AC and the Keck II Main Chiller.

The heart of the Keck II Building Glycol System is a large glycol cooler named “GC-2”. This is shown in Figure 4. It is a large fan/coil unit that cools the building glycol by means of a large fan driven by an electric motor. The more heat that is injected into the building glycol, the more the fan runs to cool the glycol. Virtually every watt of electricity consumed by NGAO is ultimately removed by this building glycol system.

The baseline design, and the initial performance of the Keck II building glycol system, was a building glycol supply temperature of $\sim 18^{\circ}\text{C}$. When the Keck II Laser was installed in 2001, the actual laser cooling requirements were much greater than predicted. As a fix, the building glycol setpoint was lowered to 13°C , which derated the performance of the glycol cooler since the difference between the outside air temperature and the returning (hot) glycol is less. From 2001 to the present, the Keck II building glycol system has struggled to provide 13°C in daytime, particularly when the Keck II laser is operational. This cooling deficiency drove the necessity to install a supplemental Keck II laser chiller in the Keck II mechanical room. This increased the heat load on the Keck II mechanical room. This has put stress on the machinery and electrical infrastructure of the Keck II telescope.

When the Keck II laser is retired, several positive things will occur for the Keck II building glycol system. The setpoint can be raised back to 18°C , restoring the original building glycol performance. This will result in less electrical consumption overall. The Keck II laser supplemental chiller can be eliminated, which will further reduce electrical consumption. Three, retirement of the supplemental laser chiller will return the Keck II mechanical room to a proper level of heat loading.

In preparation of this report, data was acquired to determine how much capacity is in GC-2 and how much power can be assigned to LGSAO operations. It was determined that during LGSAO operations GC-2 draws a long-term average of 10.7kW. This is greater by 3.42kW than the long term average when LGSAO is inactive, 7.28kW. An analysis of the demand on the system indicates that the daytime load on GC-2 is greatest during daytime, regularly exceeding its capacity.

It is concluded that there is sufficient capacity in GC-2, assuming retirement of the Keck II laser, raising the GC-2 setpoint back to 18°C , and that NGAO uses less total power than LGSAO.

6 CONCLUSIONS

1) Does the Observatory have sufficient power for NGAO, provided LGSAO is retired?

Answer: Yes, the Observatory has sufficient power provided LGSAO is retired in advance of NGAO. The retirement of LGSAO will free approximately 97KW of power. This is more than sufficient to meet the power requirements for NGAO. Assuming an error of +50% in consumption by NGAO, there is still sufficient margin.

2) Is the delivery of power to NGAO a concern to the success of the project?

Answer: No, there are no concerns. With the retirement of LGSAO, and considering the existing power margins in the Observatory power distribution system, there is sufficient power for NGAO.

3) Is there any major, new infrastructure required to power NGAO?

Answer: Yes, an industrial UPS should be installed for NGAO. This UPS shall be sized for $\geq 40\text{kW}$, to provide sufficient UPS runtime margin and to allow for upward creep and/or unplanned excess of power consumption. A UPS system will cost approximately \$60K.

The UPS must be preceded by a large transformer to convert 480VAC to 120/208VAC. It is possible to use either the existing Keck II laser transformer (TRL, 112.5 KVA) or an abandoned-in-place transformer intended for the Outrigger Telescopes (TR3, 75kVA).

In the detailed design it will become clear whether any existing power distribution infrastructure (electrical panels, conduit, wiring, etc.) can be reused from the decommissioning of LGSAO. These items are small in relative cost, but taken as whole, electrical distribution hardware can be a significant cost item. It is likely that much of the electrical hardware used for the LGSAO can be salvaged and used for NGAO.

4) Is there sufficient cooling infrastructure to remove the heat generated by NGAO?

Answer: No, there is not sufficient cooling infrastructure to remove heat from NGAO. There is a deficiency of cooling capacity by the Keck II main chiller, but this is straightforward to remedy. This will require interconnecting the Keck I and Keck II cooling systems to make use of the excess cooling capacity in Keck I for Keck II. It will not be necessary to purchase and install additional chillers; only piping and associated hardware.

5) Is there any major, new infrastructure required to remove heat from NGAO?

Answer: Yes, as described in the answer to question #4, some means of increasing the cooling capacity of the Keck II main chiller is required. The least costly and most straightforward approach is to interconnect the Keck I and Keck II cooling systems.

7 APPENDIX B. KECK 2 ELECTRICAL ONE-LINE DIAGRAM

