

# W. M. Keck Observatory's Next Generation Adaptive Optics Facility

P. Wizinowich<sup>a</sup>, S. Adkins<sup>a</sup>, R. Dekany<sup>b</sup>, D. Gavel<sup>c</sup>, C. Max<sup>c</sup>,  
 R. Bartos<sup>d</sup>, J. Bell<sup>a</sup>, A. Bouchez<sup>b</sup>, J. Chin<sup>a</sup>, A. Conrad<sup>a</sup>, A. Delacroix<sup>b</sup>, E. Johansson<sup>a</sup>,  
 R. Kupke<sup>c</sup>, C. Lockwood<sup>c</sup>, J. Lyke<sup>a</sup>, F. Marchis<sup>c</sup>, E. McGrath<sup>c</sup>, D. Medeiros<sup>a</sup>,  
 M. Morris<sup>f</sup>, D. Morrison<sup>a</sup>, C. Neyman<sup>a</sup>, S. Panteleev<sup>a</sup>, M. Pollard<sup>a</sup>, M. Reinig<sup>c</sup>, T. Stalcup<sup>a</sup>,  
 S. Thomas<sup>c</sup>, M. Troy<sup>d</sup>, K. Tsubota<sup>a</sup>, V. Velur<sup>b</sup>, K. Wallace<sup>d</sup>, E. Wetherell<sup>a</sup>

<sup>a</sup>W.M. Keck Observatory, 65-1120 Mamalahoa Hwy., Kamuela, HI 96743 (peterw@keck.hawaii.edu).

<sup>b</sup>Caltech Optical Observatories, California Institute of Technology, 1200 E. California Blvd.,  
 Pasadena, CA 91125.

<sup>c</sup>UCO/Lick Observatory, Santa Cruz, 1156 High St., Santa Cruz, CA 95064.

<sup>d</sup>Jet Propulsion Laboratory, 4800 Oak Grove Dr., Pasadena, CA 91109.

<sup>e</sup>Dept. of Astronomy, University of California, 601 Campbell Hall, Berkeley, CA 94720-3411.

<sup>f</sup>Dept. of Physics & Astronomy, University of California, Los Angeles, Box 951547, Los Angeles,  
 CA 90095-1547.

## ABSTRACT

We report on the preliminary design of W.M. Keck Observatory's (WMKO's) next-generation adaptive optics (NGAO) facility. This facility is designed to address key science questions including understanding the formation and evolution of today's galaxies, measuring dark matter in our galaxy and beyond, testing the theory of general relativity in the Galactic Center, understanding the formation of planetary systems around nearby stars, and exploring the origins of our own solar system. The requirements derived from these science questions have resulted in NGAO being designed to have near diffraction-limited performance in the near-IR (K-Strehl  $\sim 80\%$ ) over narrow fields ( $< 30''$  diameter) with modest correction down to  $\sim 700$  nm, high sky coverage, improved sensitivity and contrast and improved photometric and astrometric accuracy. The resultant key design features include multi-laser tomography to measure the wavefront and correct for the cone effect, open loop AO-corrected near-IR tip-tilt sensors with MEMS deformable mirrors (DMs) for high sky coverage, a high order MEMS DM for the correction of atmospheric and telescope static errors to support high Strehls and high contrast companion sensitivity, point spread function (PSF) calibration to benefit quantitative astronomy, a cooled science path to reduce thermal background, and a high-efficiency science instrument providing imaging and integral field spectroscopy.

**Keywords:** Adaptive Optics, Laser Guide Star, Keck Observatory

## 1. INTRODUCTION

The current Keck II and Keck I AO systems, commissioned in 1999 and 2001 respectively, have been very successful and scientifically productive [1],[2],[3],[4]. Through 2009 a total of 244 refereed science papers were published based on data from the Keck II natural guide star (NGS) and laser guide star (LGS) AO system, as well as from the Keck Interferometer (KI) [5] that combines the AO-corrected light from both telescopes. WMKO's leadership in science with LGS AO is shown in Figure 1. A successful upgrade to the ageing wavefront control computers and cameras in 2007 has allowed these systems to remain productive [6]. An upgrade of the Keck I AO system to an LGS facility is currently underway [7] will provide improved LGS performance and facilitate LGS AO-assisted KI operation [8].

The importance of achieving the full potential of the Keck telescopes is recognized in the Observatory's Strategic Plan, which identifies continued leadership in high angular resolution astronomy as a key long-term goal. In support of this goal, and the strong and growing community demand for LGS AO, we successfully completed the second design phase, Preliminary Design, for WMKO's NGAO facility in June 2010.

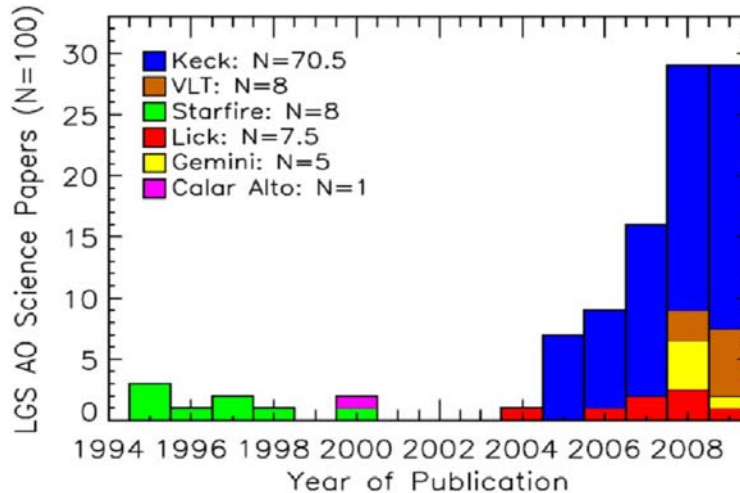

Figure 1: Peer-reviewed LGS AO science papers by year and Observatory (courtesy: M. Liu).

## 2. REQUIREMENTS

We have examined a broad range of key science goals to identify the most compelling high angular resolution science priorities of our community, and to determine what new AO characteristics are needed to realize these goals [9]. Our Science Case Requirements Document defines and analyzes two classes of science cases: “key science drivers” and “science drivers”. Key science drivers are those science cases that place the strongest or most technologically challenging demands on the performance of the NGAO system and its science instruments. These are the science cases that we have used to drive the performance requirements for the AO system and instruments. Science drivers are included to assure that the NGAO system is sufficiently flexible to deal with the broad range of science that users will demand over the lifetime of the NGAO system. The five key science drivers and nine science drivers were selected because they represented important astrophysics that would clarify the requirements on the NGAO system from different perspectives. The key science drivers include galaxy assembly and star formation history; black hole (BH) masses in nearby active galactic nuclei (AGN); precision astrometry and radial velocities for measurement of general relativity (GR) effects at the Galactic Center; imaging and characterization of extrasolar planets around low-mass stars; and multiplicity of minor planets in our solar system. The science drivers include quasar host galaxies; gravitational lensing; astrometry science in sparse fields; resolved stellar populations in crowded fields; debris disks and young stellar objects; the size, shape and composition of minor planets; the characteristics of gas giant planets, their satellites and rings; and the characteristics of ice giant planets and their rings.

The key elements of the selected NGAO architecture flow directly from the key science drivers and science drivers, and some additional system requirements imposed by the Observatory. At the highest level these can be summarized as follows:

- Near-diffraction limited performance in the near-IR (K Strehl ~80%).
- Substantially increased sky coverage.
- AO correction at wavelengths as short as 0.7  $\mu\text{m}$ .
- Improved sensitivity, contrast, photometric accuracy and astrometric accuracy.
- Imaging from 0.7 to 2.4  $\mu\text{m}$ .
- Integral field spectroscopy at R~4000 from 0.7 to 2.4  $\mu\text{m}$ .

The connection between the key science cases and the key new science capabilities of the NGAO architecture is shown in the left hand matrix of Figure 2. The connection to the resultant key architectural features, discussed in section 3, of the NGAO design is shown in the right hand matrix of Figure 2.

Key Science Drivers						Key New Science Capabilities	Key Architectural Features				
Galaxy Assembly	BH masses in nearby AGNs	GR at the Galactic Center	Planets around low-mass stars	Minor Planets			Laser tomography	AO-corrected NIR Tip-Tilt	Cooled AO	High-order DM	Science Instrument(s)
X	x	X	X	x	Near diffraction-limited in near-IR	X	X		X	X	
	X			X	AO correction at red visible wavelengths	X	X		X	X	
X	X		X	X	Increased sky coverage		X				
X		X		X	Improved sensitivity	X	X	X	X	X	
			X	X	Improved contrast	X	X		X	X	
	X		X	X	Improved photometric accuracy	X	X		X	X	
		X	X	X	Improved astrometric accuracy	X	X	X	X	X	
		X	X	X	Imaging					X	
X	X	X	X		Integral field spectroscopy					X	

Figure 2: The key new science capabilities required to achieve each key science driver result in the key NGAO architectural features (X = required, x = desirable).

### 3. DESIGN

#### 3.1 System Overview

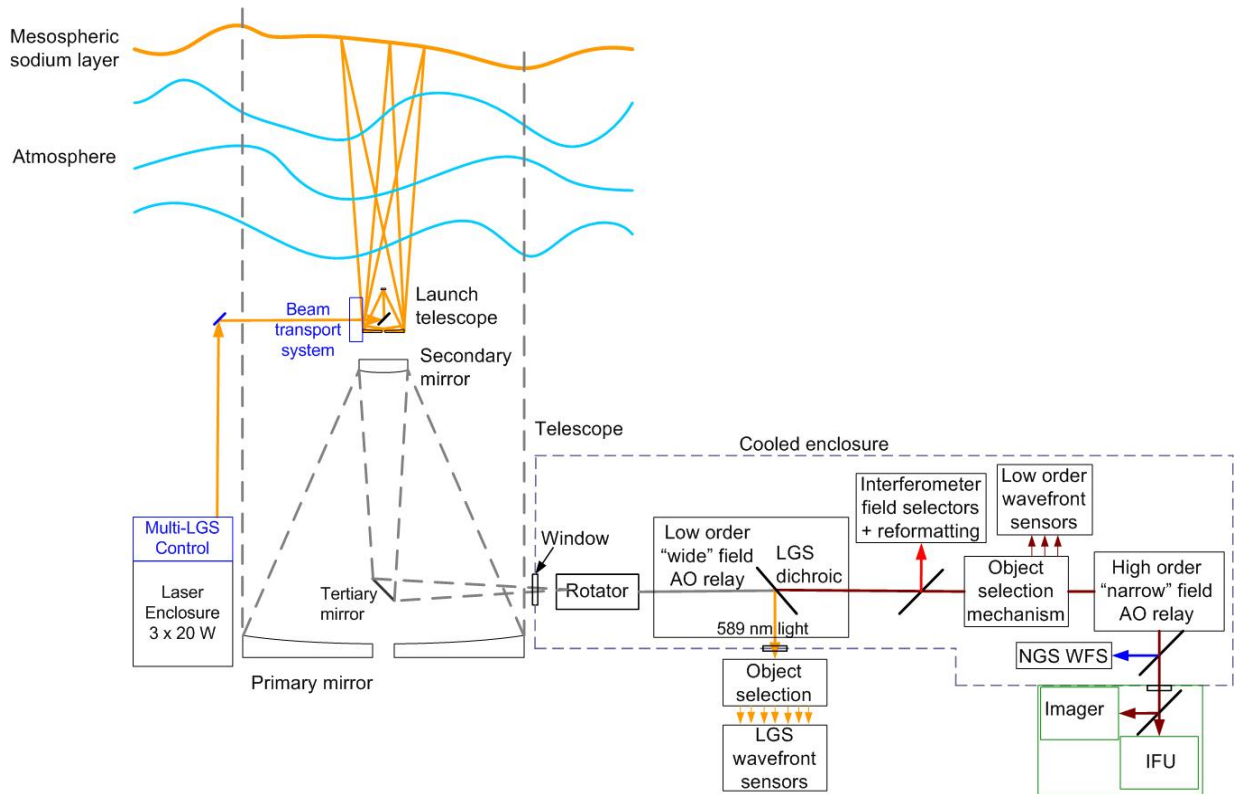

Figure 3: Schematic of the NGAO technical approach.

The NGAO technical approach is shown schematically in Figure 3. The requirement of high Strehl over a narrow field is achieved using laser tomography (to correct for focal anisoplanatism; i.e., the “cone effect”) with an on-axis LGS and three uniformly spaced LGS on a 10" radius (as illustrated in Figure 4, a narrow field relay with a DM having 60 actuators across the telescope pupil, and careful control of all sources of wavefront errors, especially tilt errors. High sky coverage is achieved by sharpening the three stars used to provide tip-tilt information with their own LGS AO systems employing patrolling LGS (shown in Figure 4) and a MEMS DM with 30 actuators across the telescope pupil (i.e., the low order wavefront sensors or LOWFS shown in Figure 3). High sensitivity at thermal wavelengths requires low emissivity which is achieved by cooling the science path optics (the cooled enclosure in Figure 3).

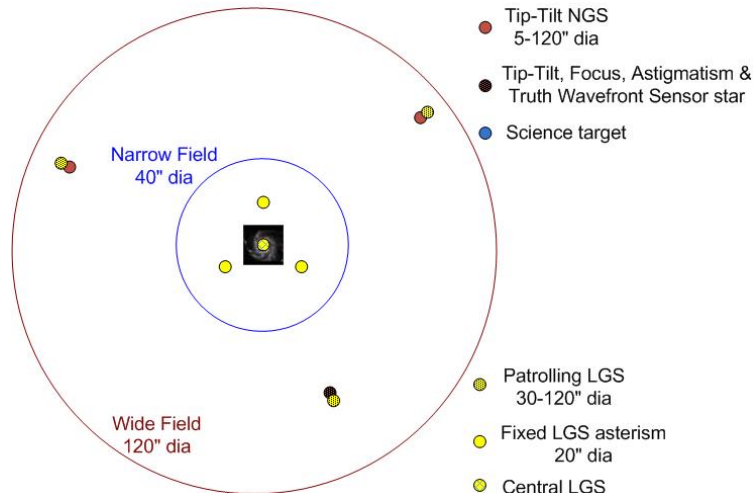

Figure 4: LGS “3+1” asterism for tomography of the central science field, plus three patrolling LGS for image sharpening two TT and one TTFA NGS.

The following is a brief summary of the key architectural features of NGAO and their flow down from the science requirements:

- Laser tomography to measure wavefronts and overcome the cone effect over the science field. This is supported by the fixed “3+1” LGS asterism and the LGS WFS.
- LGS projection from behind the telescope’s secondary mirror to minimize perspective elongation.
- Location of the AO system on the Keck II telescope left Nasmyth platform to have sufficient space for the AO system and science instruments in a gravity constant environment.
- A cooled AO system to meet the near-infrared background requirements.
- A K-mirror rotator at the input to the AO system to keep either the field or pupil fixed. The AO system would need to be cooled even without a rotator and this approach allows the most stability for the AO system and instruments.
- A wide-field (120" diameter) relay to feed light to the LGS wavefront sensors and the three LOWFS.
- A conventional (5 mm pitch) low order DM (LODM) was chosen to transmit a wide field in the wide-field relay. This DM has 20 actuators across the pupil in order to limit the size of the relay while providing closed loop AO correction to the LGS wavefront sensors to keep the LGS wavefront sensors in their linear range and to reduce the demand on downstream open loop correction.
- Open loop AO-corrected near-IR tip-tilt sensors to maximize sky coverage [10]. This is supported by three patrolling LGS, pointed slightly radially beyond the tip-tilt NGS, and corresponding LGS WFSs.
- Open loop AO-correction to the narrow field science instrument(s) in LGS mode.
- MEMS DM’s for AO-correction. These are very compact devices and have been lab demonstrated to accurately go where they are commanded. Small, modest-cost 32x32 element MEMS DM’s provide the required correction for the tip-tilt sensors. A 64x64 element MEMS, similar to that developed for the Gemini Planet Imager (GPI), is needed to provide the required AO correction to the narrow field science instrument(s) and NGS wavefront sensor. The science instruments fed by this relay only require a narrow-field (30"x30"). The narrow field facilitates the use of a single MEMS DM for the science instruments.

### 3.2 AO Opto-mechanical Design

Figure 5 and Figure 6 provide views of the AO bench and instruments from the mechanical model. Figure 7 and Figure 8 provide views of the LGS and LOWFS assemblies, respectively. Both the patrolling LGS wavefront sensors and the LOWFS use the same object selection mechanisms based on two rotational axes to insert a pickoff mirror anywhere in the 120" diameter field of view. The NGS wavefront sensor instead uses a pair of steering mirrors to keep the pupil fixed while selecting a star anywhere in a 40"x60" field. Figure 9 provides a partially transparent view through the walls of the left Nasmyth platform enclosure that will house the AO bench, the science instruments and the electronics.

The NGAO science instrument, DAVINCI, the Diffraction limited Adaptive optics Visible and Infrared iNtegral field spectrograph and Coronagraphic Imager, is a cryogenic imager and integral field spectrograph operating from 0.7  $\mu\text{m}$  to 2.4  $\mu\text{m}$  [11]. The imaging mode uses a fixed pixel scale of 7 mas and provides diffraction limited imaging using a Teledyne Hawaii-4RG detector. The central portion (~6") of the DAVINCI FOV can be sent to the IFS, allowing simultaneous spectroscopy and imaging. The IFS has a sampling format of 112 x 60 samples and is optimized for narrow band observations (~5% bandpass). The IFS uses a lenslet image slicer combined with novel reformatting optics to provide 6 virtual slits (680 pixels per spectra) on a Hawaii-4RG detector. Three spatial sampling scales are provided, 10, 35, and 50 mas resulting in FOVs of 1.12" x 0.6", 3.92" x 2.1", and 5.6" x 3". Fixed gratings are provided for each major waveband, operating in the first order near the peak of the blaze function with  $R \sim 4,000$ .

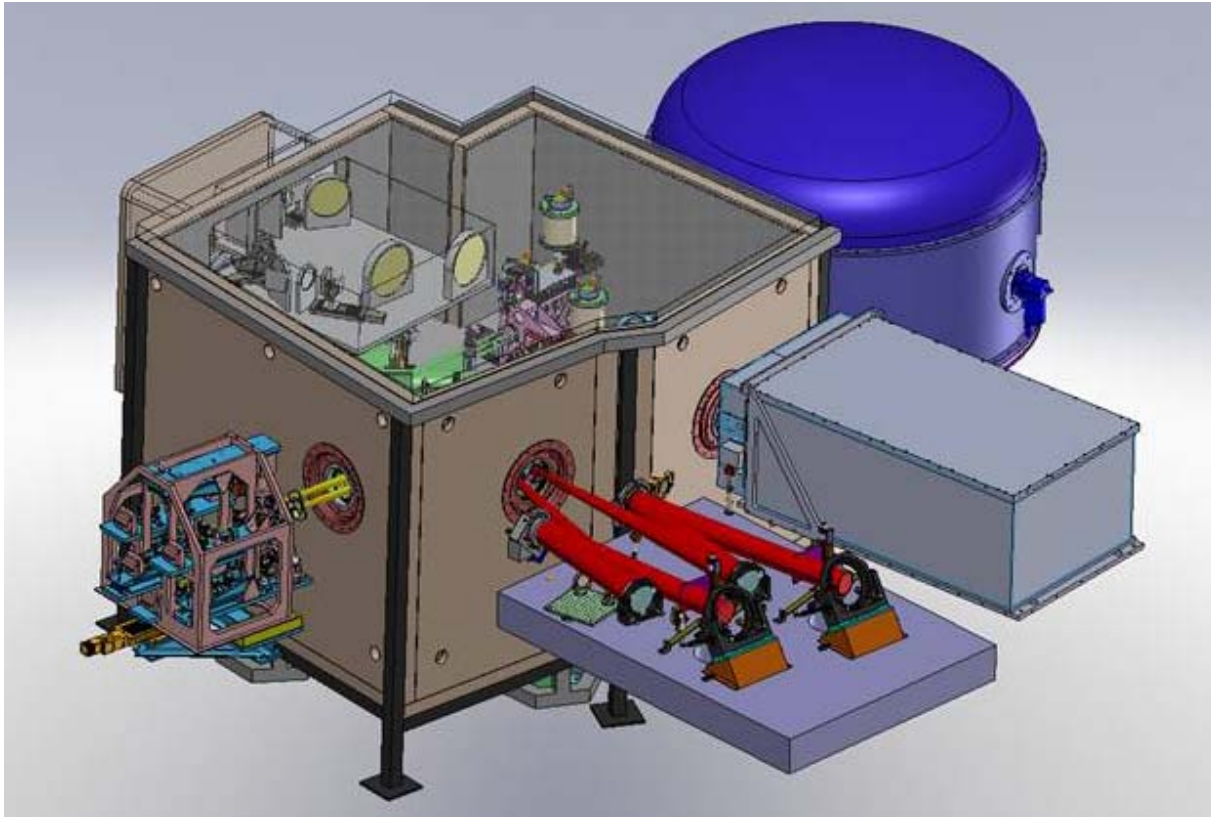

Figure 5: Perspective view of the NGAO system and science instruments at Nasmyth.

*The AO bench is shown with the cold enclosure top cover removed. This enclosure is surrounded by, from left to right, the LGS WFS assembly, the interferometer dual star module, a future science instrument and DAVINCI.*

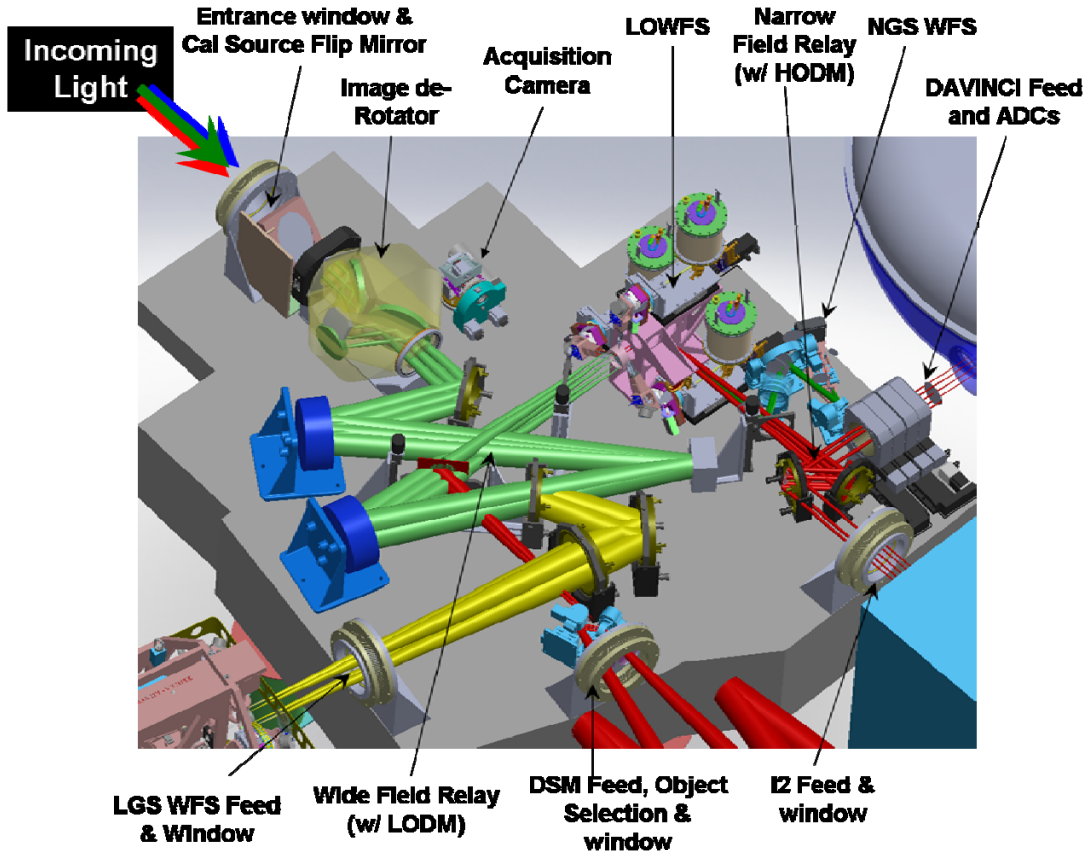

Figure 6: Perspective view of the AO bench with major components labeled.

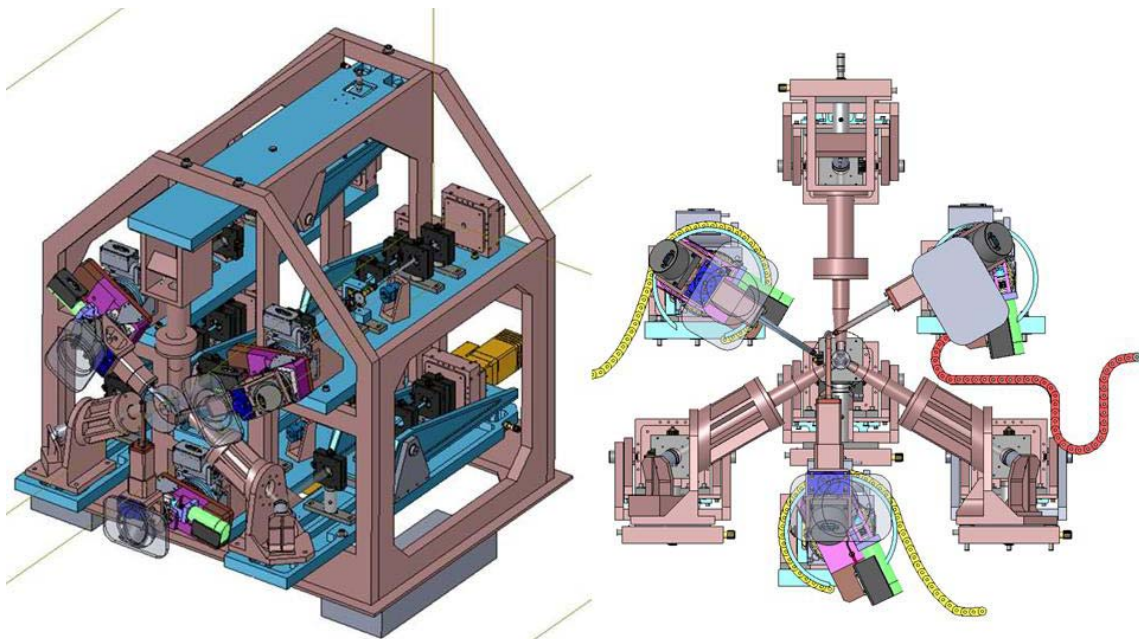

Figure 7: LGS wavefront sensor assembly perspective (left) and front view (right). Four fixed and 3 patrolling LGS WFS mounted on a common focus tracking stage.

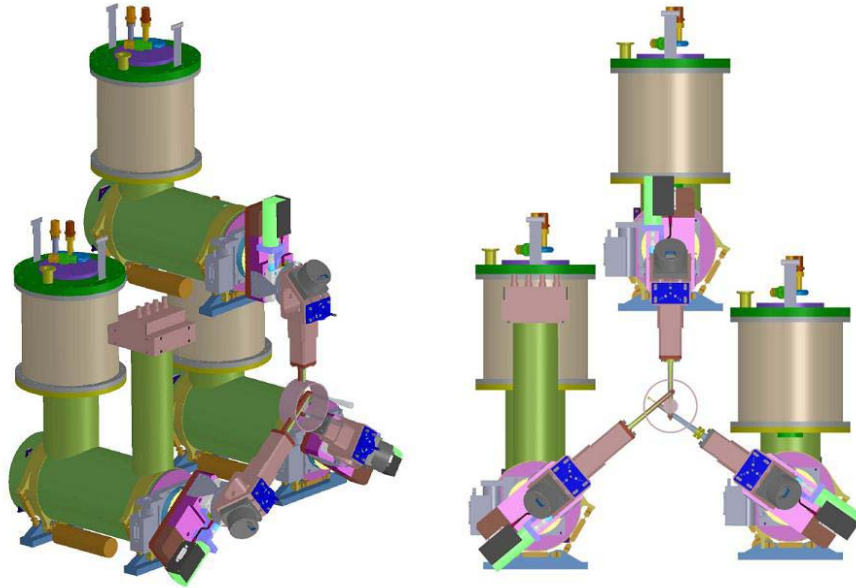

Figure 8: Low order wavefront sensor (LOWFS) assembly perspective (left) and front (right) views.  
*The 3 LOWFS probe arms move over the 120" diameter field of view indicated by the central circle in the right figure.*

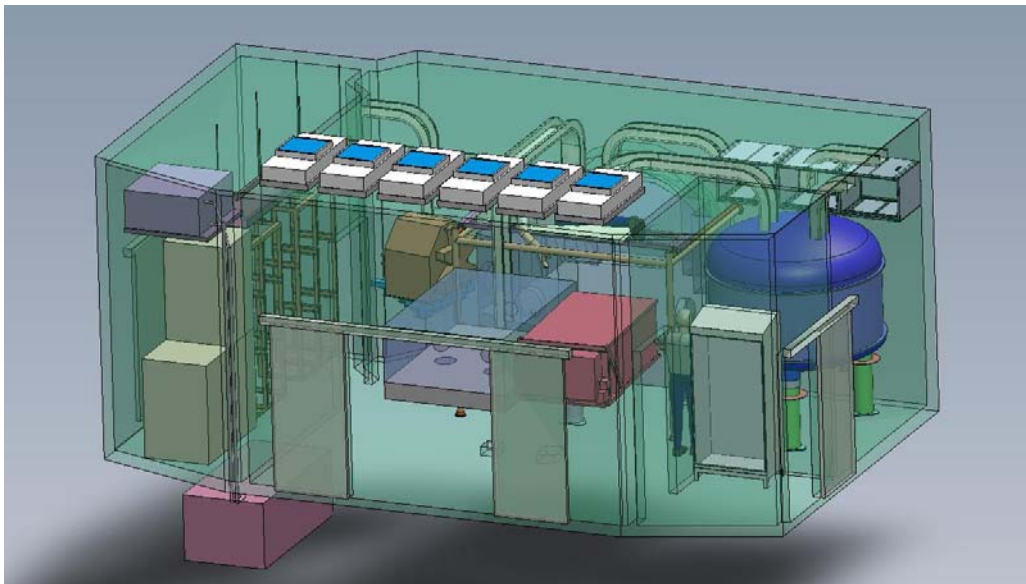

Figure 9: Transparent perspective view of the Nasmyth platform enclosure.

### 3.3 LGS Facility

The Laser Guide Star Facility (LGSF) is responsible for generating the seven laser beacon asterism shown in Figure 4. The LGSF is divided into four subsystems: three 20 W lasers, a laser enclosure to house the lasers, a Laser Launch Facility (LLF) and a Safety System. A laser manufacturer, TOPTICA/MPBC, has been identified through a down selection process that included committee members from ESO, TMT, and WMKO. During this phase, the manufacturer produced a lab demonstrator unit that meets the required laser performance levels and completed a preliminary design. The manufacturer will continue into the final design phase which includes a functioning pre-production unit.

The 20 W CW lasers, which include back-pumping, can be partitioned into two subsystems, the laser heads producing the 589 nm generation, and the control electronics and pump diodes. The laser heads will be mounted within a laser enclosure located on the Keck II telescope's elevation ring. The electronics and pump diodes will be located in the

temperature controlled AO electronics vault on the left Nasmyth platform. Fibers will be used to transfer the beams from the pump diodes to the laser heads. The laser enclosure currently supports the existing Keck II dye laser table. This table will be removed and replaced with the three laser heads as shown in Figure 10.

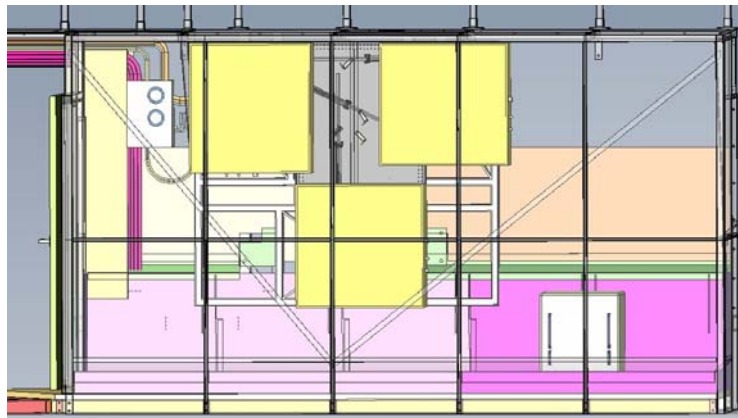

Figure 10: Elevation view of the laser enclosure layout to support three new lasers.  
*The 3 laser heads are shown as yellow boxes.*

The LLF receives the three laser beams and generates the seven beams exiting the laser launch telescope mounted behind the Keck II secondary mirror. The first subsystem in the LLF is the Switchyard. The Switchyard formats and steers the three laser beams into Beam Transport Optics on the telescope and the Beam Generation System (BGS) located behind the telescope secondary mirror. The Switchyard compensates for telescope flexure as well as possible vibration in the telescope structure. The BGS receives the three laser beams and generates the laser asterism using a series of beam splitters and mirrors (Figure 11). The BGS positions both the fixed and patrolling lasers and maintains their position via feedback from the LGS wavefront sensors. Included in the BGS and Switchyard are diagnostics to ensure optimum laser performance and asterism positions. The final element in the LLF is an  $f/1.4$  Launch Telescope (LT) that sends the seven beams into the Mesosphere. A manufacturer has been contracted to provide this telescope, which is similar to the Keck I LGS AO System LT.

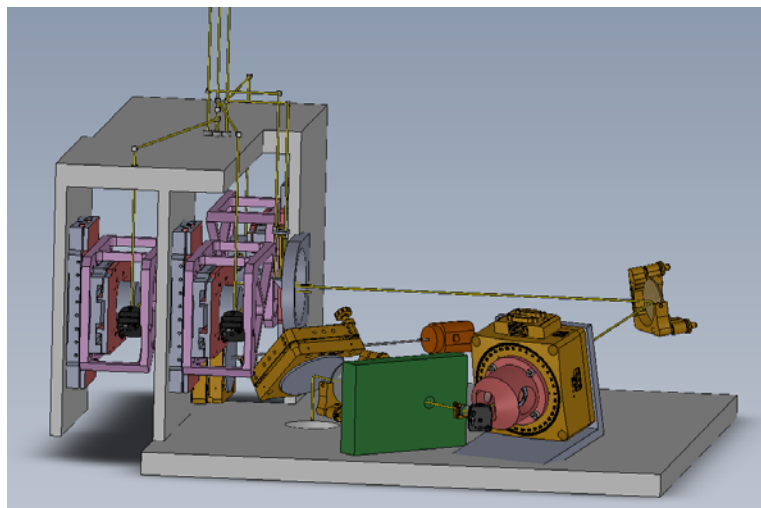

Figure 11: Beam Generation System

The final LGSF subsystem is the Safety System that ensures the safety of personnel and equipment through a series of interlocks. The safety system uses a programmable logic controller which senses the laser environment, including aircraft spotters to terminate laser output if necessary. The safety system also works in conjunction with a Mauna Kea Laser Traffic Control System to minimize contamination of astronomical observations, the Laser Clearinghouse for satellite protection, and an Aircraft Safety System to protect aircraft in the Mauna Kea airspace.



### 3.4 AO Controls

The AO control system is integrated with the telescope’s overall control system and has its own hierarchy for controlling the operation of the AO system in coordination with the instruments. Lessons learned from prior AO control system development have been taken advantage of in the design of the NGAO system, with particular attention paid to operations planning, efficient observations, and data archiving.

The NGAO control architecture, shown hierarchically in Figure 12, is distributed among several subsystems: science instruments, AO system, telescope interface, laser system, data server, atmospheric tools and the laser traffic control system. The overall system is operated through the user interface and operations tools at the topmost layer of control. The science operations tools control the AO facility through a high level sequencer (the multi-system sequencer). The multi-system sequencer sends parallel commands to each of subsystem sequencer. The sequencing is performed at the lowest possible levels allowing for parallel (time efficient) observing sequences. The middle level of the hierarchy represents the basic control functions for that subsystem. Some users will access the system at this middle level for engineering or troubleshooting purposes, but observing operations will occur via the topmost layer. Shown at the lowest level of the hierarchy are the controlled devices themselves.

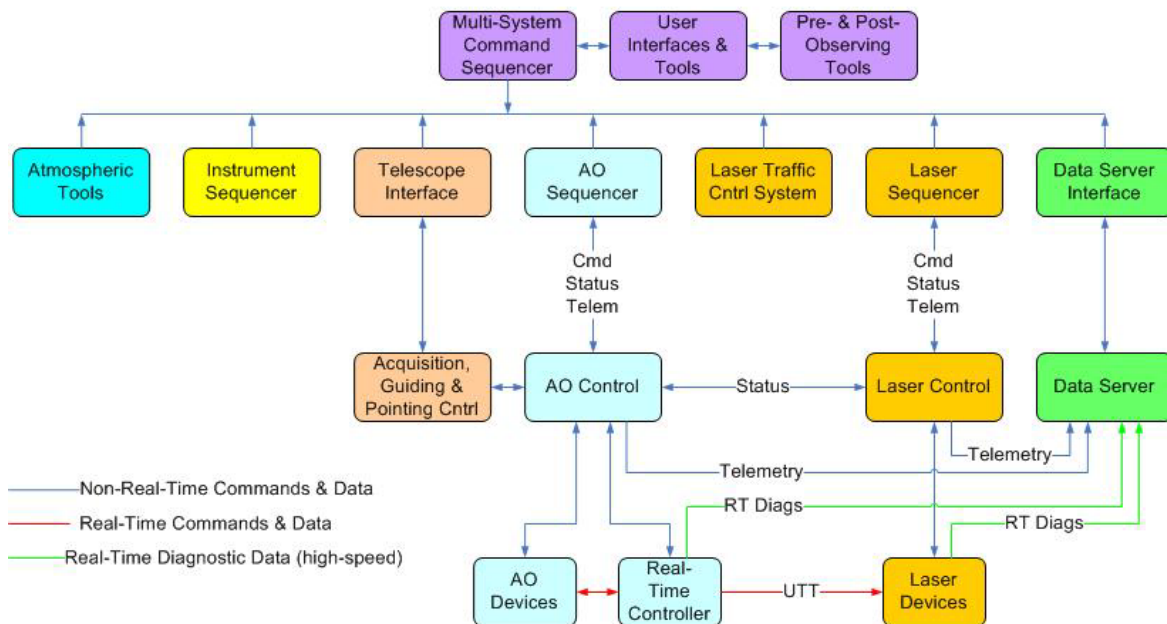

Figure 12: NGAO system distributed control system block diagram.

The Real Time Controller (RTC) is designed to perform all of the wavefront sensing, tomography calculations, and deformable mirror control processing at rates that keep up with atmospheric turbulence induced optical aberrations [12]. The RTC data flow and computer architectures have been designed to achieve the tomography precision, noise suppression, and bandwidth requirements implied by the science-case driven wavefront error budgets.

An equally important RTC design consideration is the need to keep the cost and complexity manageable. Simply scaling earlier implementations of RTCs for single conjugate AO wavefront reconstructors using traditional central processing units (CPUs) is infeasible because of the multiplicative increase in computing load resulting from multiple LGS and multiple DMs. To address this issue, we have taken advantage of parallel wavefront reconstruction and tomography algorithms mapped on to a massively-parallel processing (MPP) compute architecture. This architecture scales in size and complexity much more favorably than doing the same calculations on CPUs. The MPP architecture can be readily implemented with commercial off the shelf technology building blocks (i.e., field programmable gate arrays).

As shown schematically in Figure 13, large chunks of compute tasks are associated with either wavefront sensors or DM’s and thus can be parallelized across them. Furthermore, algorithms running within the sensor and actuator subunits, as well as within the tomography engine, are highly parallelizable when implemented in the Fourier domain, and thus will each map onto an MPP architecture.

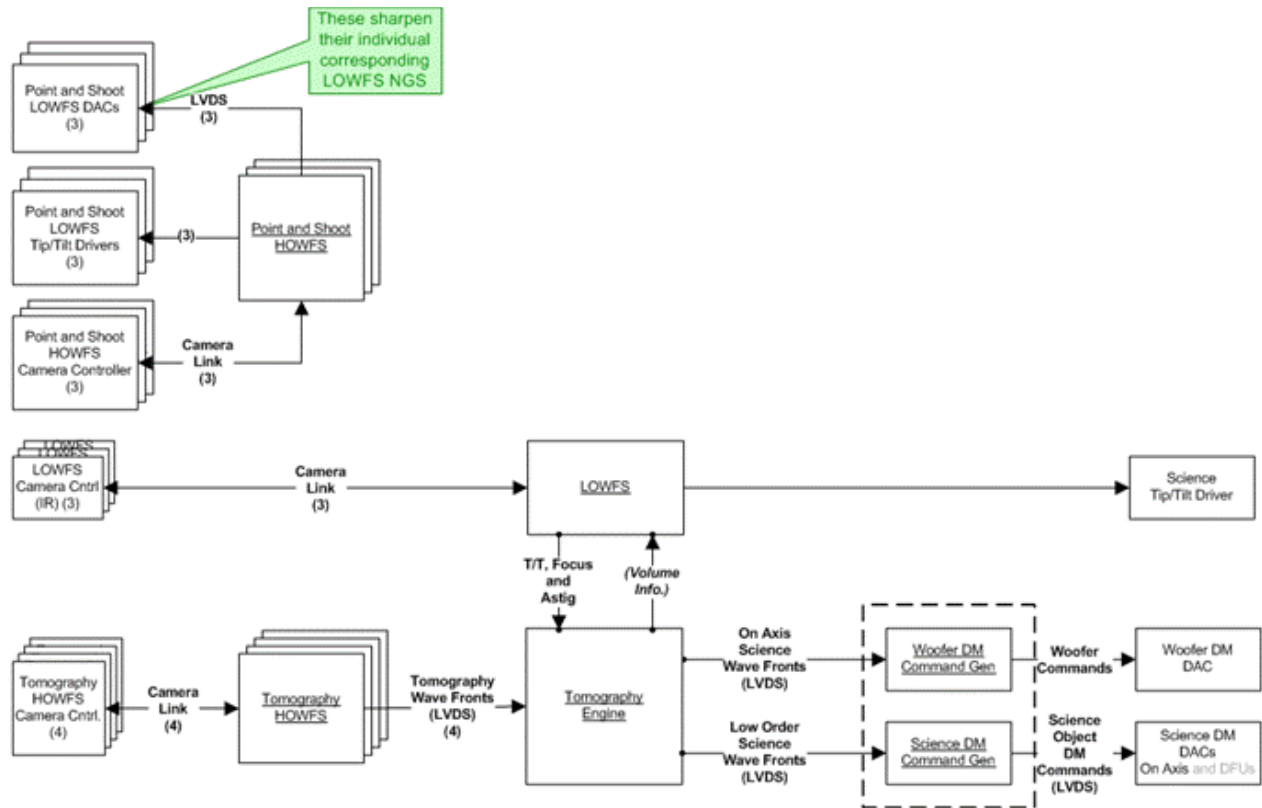

Figure 13: Multi-guide star tomography data flow and parallel processing.

#### 4. PERFORMANCE

The predicted performance of the current NGAO design under median conditions is shown in Table 1 for each of the key science drivers and for one NGS AO case. The performance is robust under degrading conditions (poorer seeing, reduced laser return, increased zenith angle, etc.) and variations in design assumptions.

Table 1: NGAO predicted performance for the key science case drivers (1-5) and one NGS AO case (6).

Case #	Science Case	Science Band	RMS High-order Wavefront Error (nm)	RMS Tip-Tilt Error (mas)	Effective RMS Wavefront Error (nm)	Strehl Ratio	Ensquared Energy in Spaxel			
							10 mas	35 mas	50 mas	70 mas
1	Galaxy Assembly	K	158	4.9	180	77%	4%	36%	56%	75%
2	Nearby AGN	Z	158	4.8	176	21%	8%	29%	30%	31%
3a	Galactic Center Imaging	K	208	2.2	212	69%	4%	31%	48%	65%
3b	Galactic Center Spectra	H	191	2.4	195	57%	5%	38%	52%	59%
4	Exo-planets	H	155	2.9	162	68%	6%	46%	62%	71%
5	Minor Planets	Z	157	4.7	175	21%	8%	29%	30%	31%
6	Io	Z	116	2.1	119	48%	14%	51%	53%	53%

The sky coverage provided by the near-IR AO-corrected LOWFS is excellent as shown by the Figure 14 plot of galaxy assembly case performance versus sky coverage. The performance improvement over existing Keck AO is dramatic as shown by the Monte Carlo estimate simulating 44 observations over a random range of conditions shown in Figure 15. The on-sky data shown in this plot is from a 2005 to 2007 brown dwarf survey program using Keck LGS AO and typically faint off-axis guide stars (no data has been discarded) [13].

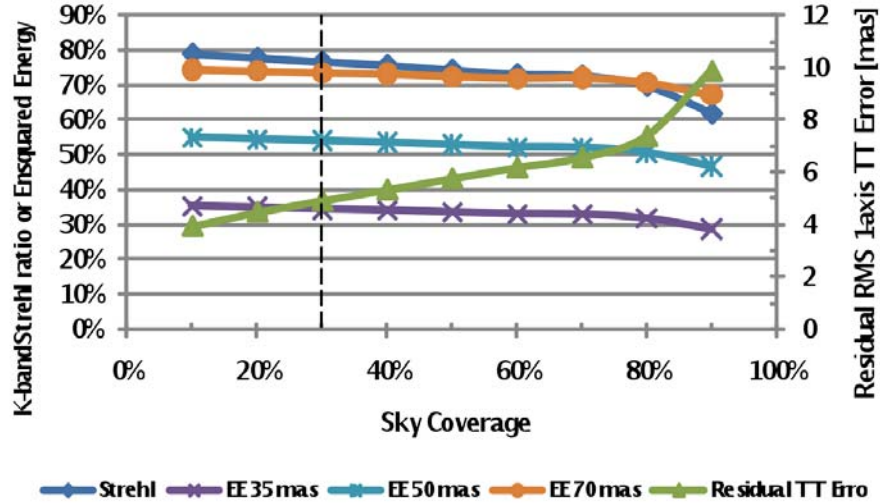

Figure 14: K-band Strehl, ensquared energy (within 35, 50 and 70 milli-arcseconds) and residual tip-tilt error versus sky coverage for the galaxy assembly science case (30° zenith angle, 60° galactic latitude and 30 minute integration). The vertical dashed line is the 30% sky coverage case listed in Table 1.

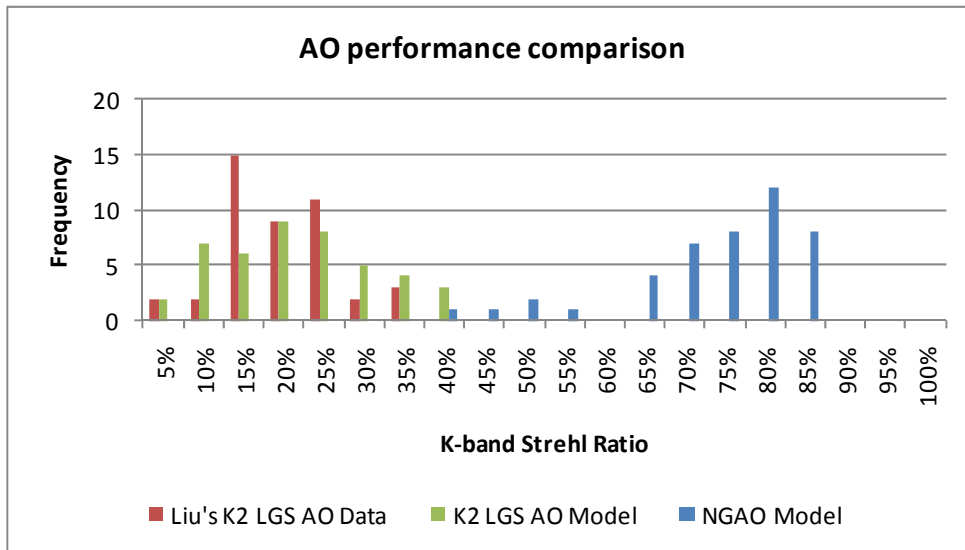

Figure 15: Comparison of current Keck AO performance (actual data and model) to NGAO performance.

## 5. SCHEDULE

Figure 16 shows the key milestone of the first science night for each new Keck AO capability since 1999. Past AO capabilities that have been turned over to science operations are shown up through 2007. The next new capability, to be available in 2011, is an LGS AO upgrade of the Keck I AO system which will allow LGS AO science on both Keck telescopes. The Keck II laser is currently projected from the side of the Keck telescope; we have received NSF MRI funding to implement a laser launch telescope behind the telescope secondary mirror for use with the existing AO system and later with NGAO. We have also received NSF ATI funding to implement a near-IR tip-tilt sensor for improved sky coverage on an existing Keck AO system. A proposal for the first NGAO laser has been submitted to the NSF MRI program; if funded it would replace the existing Keck II dye laser.

The NGAO project successfully completed its preliminary design review in June 2010. We are currently awaiting funding and the approval to proceed with the NGAO detailed design phase which is expected to take 2 years. The current schedule has first NGAO science in late 2015.

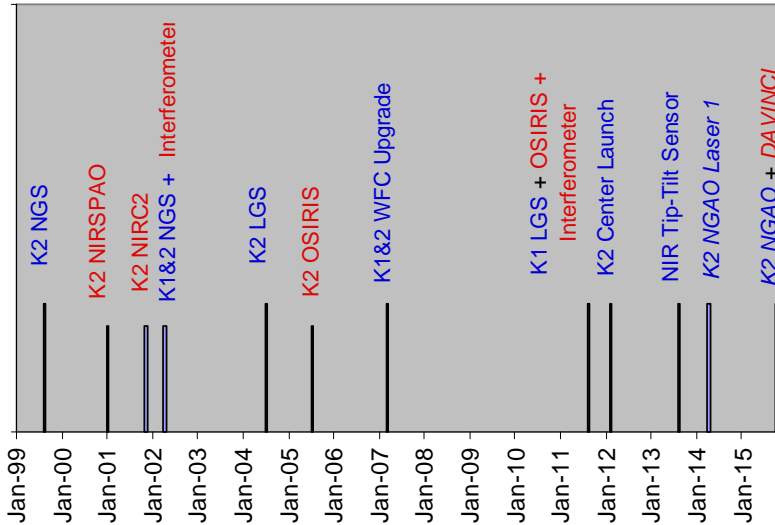

Figure 16: First allocated science nights, past and future, for new Keck AO capabilities.

## 6. CONCLUSION

We have embarked on the design of a Next Generation AO facility for the WMKO that should enable a broad spectrum of new and cutting-edge science through improved sensitivity, higher Strehls, improved PSF knowledge and stability, increased sky coverage, performance at shorter wavelength and new science instrument capabilities. In this paper we have presented elements of the preliminary design for this system.

## ACKNOWLEDGEMENTS

The W. M. Keck Observatory is operated as a scientific partnership among the California Institute of Technology, the University of California, and the National Aeronautics and Space Administration. The Observatory was made possible by the generous financial support of the W. M. Keck Foundation. The NGAO preliminary design was supported by AURA (AST-0335461) through the National Science Foundation's Telescope Systems Instrumentation Program.

## REFERENCES

- [1] P. Wizinowich et al., "Adaptive Optics Developments at Keck Observatory," SPIE Proc. 6272-09, 2006.
- [2] P. Wizinowich et al., "The W.M. Keck LGS AO System: Overview," PASP 118, 297-309, 2006.
- [3] R. Campbell et al., "AO Operations at the W.M. Keck Observatory," SPIE Proc. 7016-002, 2008.
- [4] S. Adkins et al., "Advances in Instrumentation at the W.M. Keck Observatory," SPIE Proc. 7735-1, 2010.
- [5] S. Ragland et al., "Recent Progress at the Keck Interferometer," SPIE Proc. 7734-1, 2010.
- [6] E. Johansson et al., "Updating the Keck AO Systems with a Next Generation WaveFront Controller," SPIE Proc. 7015-121, 2008.
- [7] J. Chin et al., "Keck I laser guide star AO system integration," SPIE Proc. 7736-66, 2010.
- [8] J. Woillez et al., "ASTRA: The astrometric and phase-referencing astronomy upgrade for the Keck Interferometer," SPIE 7734-37, 2010.
- [9] C. Max et al., "The Science Case for the Next Generation AO System at W.M. Keck Observatory," SPIE Proc. 7015-225, 2008.
- [10] R. Dekany, et al., "Sharpening low-order NGS using patrolling laser guide stars," SPIE Proc. 7015-25, 2008.
- [11] S. Adkins et al., "A high-performance imager and integral field spectrograph for the W. M. Keck Observatory's next-generation adaptive optics facility," SPIE Proc. 7735-287, 2010.
- [12] M. Reinig, D. Gavel, "Real-time control for Keck Observatory next-generation adaptive optics," SPIE Proc. 7736-130, 2010.
- [13] M. Liu, "LGS AO Science Impact: Present and Future Perspectives," SPIE Proc. 7015-08 (2008).