

NGAO OSM

Design Study

Alex Delacroix

06/15/2009

Version 4

Conceptual design and operation

The $\varnothing 5''$ (3.635 mm) probe covers the entire $\varnothing 120''$ (87.24 mm) Field of View.

The 2 degrees of freedom probe arm consists of 2 individual arms: A crank arm and a lever arm, driven by 2 corresponding rotation motors: The crank and lever motors.

Any position in the OSM field of view can be acquired by calculating appropriate values for theta and phi, noting that due to a mirror reflection there are always 2 possible solutions.

The crank motor is secured to the Sensor and rotates the crank arm, precisely about the rotation axis of the crank motor referred to as the theta axis. The lever arm motor provides the necessary second degree of freedom by rotating the lever arm and all associated optics, about the phi axis.

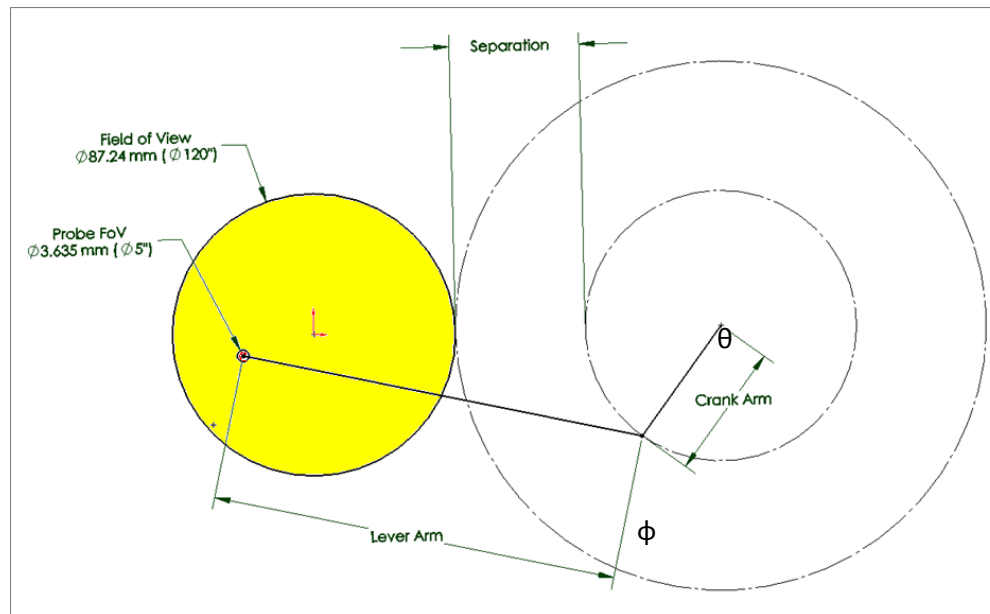

Basic Design requirements:

Mechanism Type:	ϕ/θ
Patrolled Field:	$\varnothing 120''$ (87.24mm)
Probe FoV:	$\varnothing 5''$ (3.635mm)
Acquisition accuracy:	40 mas (30 μ m)
Stability:	5 mas / 3600s (1 μ m)
Position knowledge:	< 1 μ m (TBC)
Minimum Incremental motion:	TBD
Operating Temperature:	-10°C +/- 0.3

Note: Separation is a distance determined by the Lever Arm motor envelope.

Position Accuracy

Probe Position within the field shall be measured according to the level of desired accuracy: Direct or indirect.

Indirect measurement:

Total Position Accuracy of 30 μ m at the furthest position across the 144mm field requires a minimum crank rotation accuracy of:

$$\sin \alpha = 30\mu\text{m} / 144 \text{ mm} \rightarrow \alpha = 0.012^\circ = .012 \pi / 180 = .00021 \text{ rad} = 210 \mu\text{rad}$$

And the 100 mm lever arm motor is 60 % longer than the 40mm Crank arm

Crank motor rotation accuracy: 210 μ rad x 60% = 126 μ rad

Lever motor rotation accuracy: 210 μ rad x 40% = 84 μ rad

Arms Size Equation

Arm fully extended Equation:

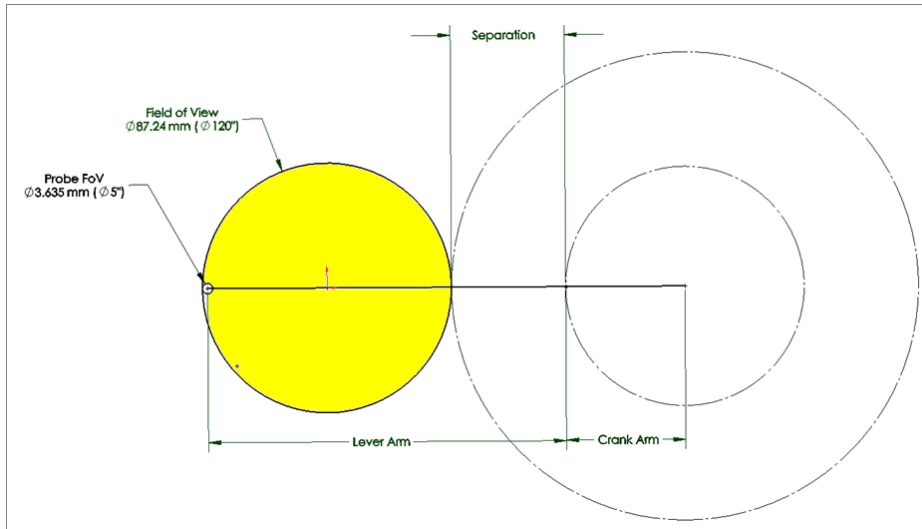

$$\text{Lever Arm} + \text{Crank Arm} + \text{Probe} = \text{Fov} + \text{Separation} + \text{Crank Arm}$$

$$\text{Lever Arm} + 1.8175 = 87.24 + 40$$

$$\rightarrow \text{Lever Arm} = 125.42 \text{ mm}$$

Arm fully retracted Equation:

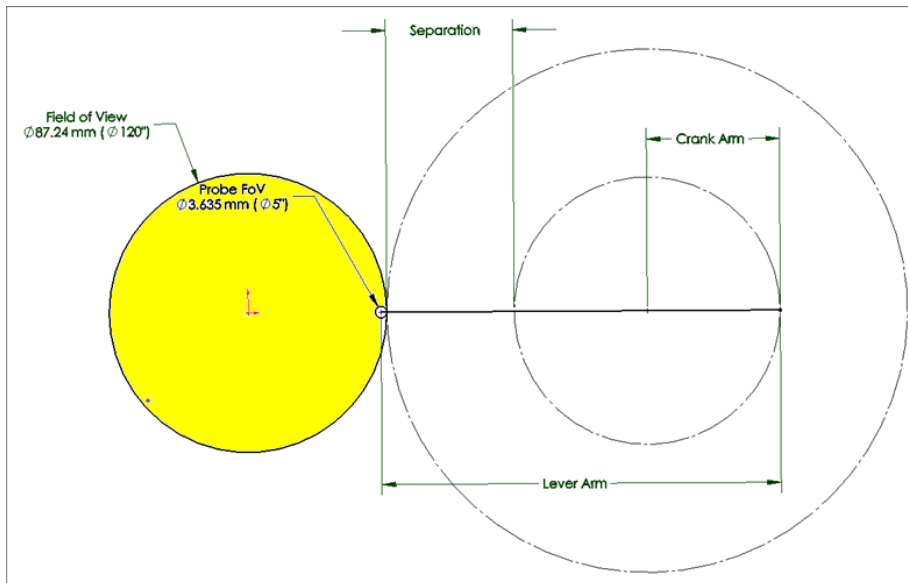

$$\text{Lever Arm} - \text{Crank Arm} = \text{Separation} + \text{Crank Arm} + \text{Probe}$$

$$\rightarrow \text{Crank Arm} = 41.30 \text{ mm}$$

Servo Motors Vs Stepper Motors

Motion Characteristics	Servo Motors	Stepper Motors
High Torque, Low Speed	Can be considered if cost/ complexity is not an issue.	Continuous duty applications requiring high torque and low speed.
High Torque and high speed (>2000 rpm)	<p>Continuous duty applications requiring high torque and high speed.</p> <p>DC servomotor can deliver greater continuous shaft power at high speeds compared to steppers. High speed up to 12000 rpm is possible.</p> <p>AC servo motors can handle higher current surges compared to DC servos.</p> <p>Can get lot stronger AC servo compared to either DC servo or DC stepper.</p>	<p>If speeds are less than 2000 rpm stepper may be economical.</p> <p>Stepper becomes bulky at high torque.</p>
Short, Rapid Repetitive Moves	Use servo if need high dynamic requirements.	Stepper will offer more economic solution when requirements are more modest.
Positioning Applications	Servo can handle effectively when load is mostly inertia instead of friction. The ability to overdrive servo motor in intermittent duty allows a smaller motor to be used. If positioning is critical in micron level use servo.	Use stepper motor if torque is lower than 500 oz-in, less 2000 rpm, low to medium acceleration rates.
Applications in Hazardous Environments	Use brushless servo motor.	Use step motor.
Low Speed, High Smoothness	Use DC servo.	Use microstepping.
Control Method	Closed loop.	Preferred to be used in open loop applications.

Potential Lever Motor

PI M-037.DG Rotation stage

M-037 rotation stages are equipped with ultra-precise worm gear drives allowing unlimited rotation in either direction.

An integrated spring preload eliminates backlash.

Double-row ball bearings allow zero backlash, high load capacity and extremely low wobble.

Model M-037.DG is closed-loop DC motors with shaft-mounted position encoders and precision gearheads providing 3.5 μrad at a design resolution of 0.6 μrad .

Model M-037.2S models feature a cost-effective directdrive, 2-phase stepper motor, providing very smooth operation and a resolution of 5.45 μrad at a minimum incremental motion of 21 μm .

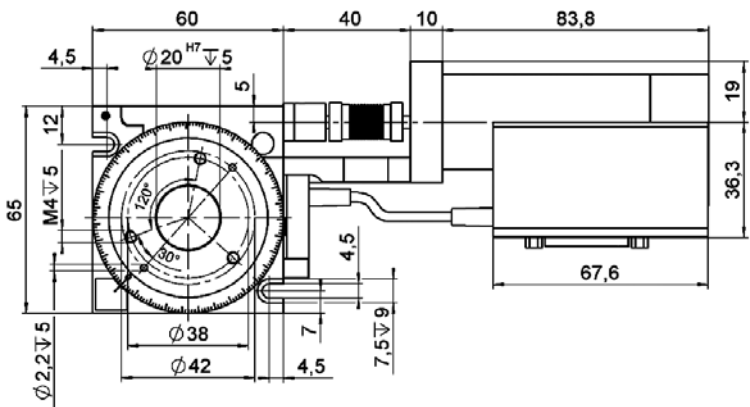
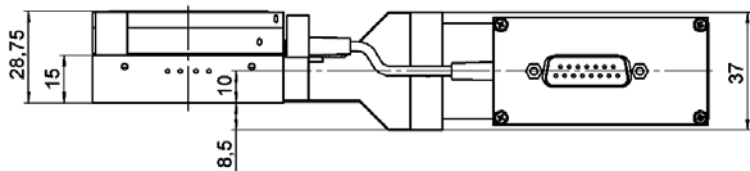

Technical Data

Model	M-037.00	M-037.DG	M-037.PD	M-037.2S
Active axes	Rotation	Rotation	Rotation	Rotation
Motion and positioning				
Rotation range	>360	>360	>360	>360
Integrated sensor	-	Rotary encoder	Rotary encoder	-
Sensor resolution	-	2000	4000	-
Design resolution	-	0.59 (34 x 10 ⁻⁶)	3.75 (0.0005)	5.45* (0.00031)
Min. incremental motion	-	3.5	27	21
Backlash	-	200	200	200
Unidirectional repeatability	-	30	30	30
Wobble	<150	<150	<150	<150
Max. velocity	-	6	45	10
Mechanical properties				
Worm gear ratio	180:1	180:1	180:1	180:1
Gear ratio	-	(28/12)* = 29.6:1	-	-
Motor resolution	-	-	-	6400*
Load capacity/axial force, self-locking	±300	±300	±300	±300
Max. torque (θ ₁ , θ ₂)	±3	±3	±3	±3
Max. torque clockwise (θ ₂)	1	1	1	1
Max. torque counter clockwise (θ ₂)	0.5	0.5	0.5	0.5
Drive properties				
Motor type	-	DC motor, gearhead	ActiveDrive™ DC Motor	2-phase stepper motor*
Operating voltage	-	0 to ±12	24 (PWM)	24
Electrical power	-	3	30	-
Reference switch	-	Hall-effect	Hall-effect	Hall-effect
Miscellaneous				
Operating temperature range	-20 to +65	-20 to +65	20 to +65	-20 to +65
Material	Aluminum	Aluminum	Aluminum	Aluminum
Mass	0.3	0.65	0.62	0.64
Recommended controller/driver	-	C-863 (single-axis) C-843 PCI-Karte (for up to 4 axes)	C-863 (single-axis, p. 4-114) C-843 PCI-Karte (p. 4-120) (for up to 4 axes)	C-663 (single-axis, p. 4-112)

incl. motor cable, 3 m, sub-D connector 15-pin

*2-phase stepper motor, 24 V chopper voltage, max. 0.8 A/phase, 400 full steps/rev., motor resolution with C-663 stepper motor controller



M-037.DG rotation stage with DC Motor and gearhead

Potential Crank Motor

PI M-038.DG Rotation stage

Model M-038.DG1 equipped with a closed-loop DC motor with shaft-mounted position encoder and precision gearhead providing minimum incremental motion of 3.5 μrad at a design resolution of 0.6 μrad .

Model M-038.2S1 models feature a cost-effective directdrive, 2-phase stepper motor, providing very smooth operation and a resolution of 5.45 μrad at a minimum incremental motion of 21 μm .

ActiveDrive™

Model M-038.PD is equipped with the highly efficient Active Drive™ direct drive and reaches velocities up to 45°/s. The ActiveDrive™ design, developed by PI, features a high-efficiency PWM (pulse width modulation) servo-amplifier mounted side-by-side with the DC motor and offers several advantages: Increased efficiency, by eliminating power losses between the amplifier and motor. Reduced cost of ownership and improved reliability, because no external driver is required. Elimination of PWM amplifier noise radiation, by mounting the amplifier and motor together in a single, electrically shielded case.

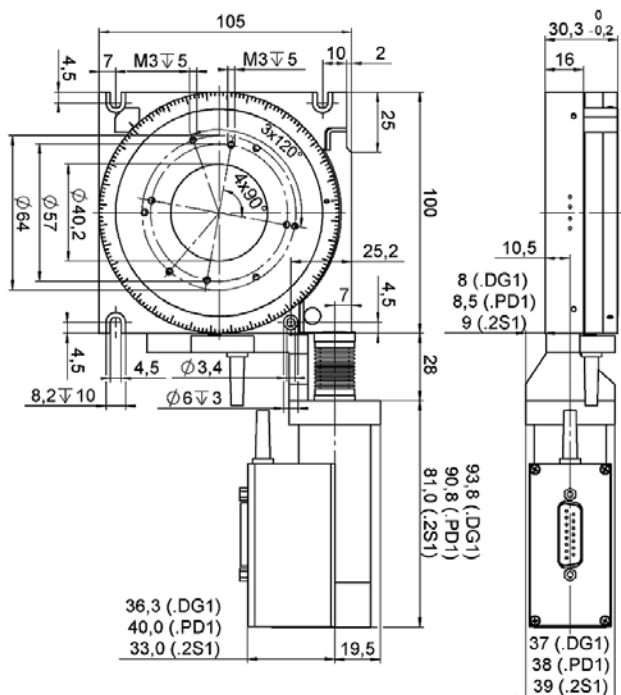

Technical Data

Model	M-038.001	M-038.DG1	M-038.PD1	M-038.2S1	Units
Active axes	Rotation	Rotation	Rotation	Rotation	
Motion and positioning					
Rotation range	>360°	>360°	>360°	>360°	
Integrated sensor	-	Rotary encoder	Rotary encoder	-	
Sensor resolution	-	2000	4000	-	steps/rev.
Design resolution	-	0.60 (35 x 10 ⁻⁴)	8.95 (0.0005)	5.58* (0.00032)	μrad (°)
Min. incremental motion	-	3.5	27	21	μrad
Backlash	-	200	200	200	μrad
Unidirectional repeatability	-	20	20	20	μrad
Wobble	<75	<75	<75	<75	μrad
Max. velocity	-	6	90	10	°/s
Mechanical properties					
Worm gear ratio	176:1	176:1	176:1	176:1	
Gear ratio	-	2401:81 = 29.6:1	-	-	
Motor resolution	-	-	-	6400*	steps/rev.
Max. load/axial force	± 400	± 400	± 400	± 400	N
Maximum torque (θ_x, θ_y)	± 6	± 6	± 6	± 6	
Maximum torque CW**	2	2	2	2	Nm
Maximum torque CCW**	0.8	0.8	0.8	0.8	Nm
Drive properties					
Motor type	-	DC Motor, gearhead	ActiveDrive™ DC Motor	2-phase stepper motor*	
Electrical power	-	3	30		W
Reference switch	-	Hall-effect	Hall-effect	Hall-effect	
Miscellaneous					
Operating voltage	-	12 V differential	24 (PWM)	24	V
Operating temperature range	-20 to +65	-20 to +65	-20 to +65	-20 to +65	°C
Material	Aluminum	Aluminum	Aluminum	Aluminum	
Mass	0.9	1.25	1.35	1.25	kg
Recommended controller/driver		C-863 (single-axis) C-843 PCI board (for up to 4 axes)	C-863 (single-axis, p. 4-114) C-843 PCI board (p. 4-120) (for up to 4 axes)	C-663 (single-axis, p. 4-112)	

*2-phase stepper motor, 24 V chopper voltage, max. 0.8 A/phase, 400 full steps/rev., motor resolution with C-663 stepper motor controller
**CW: clockwise; CCW: counter-clockwise

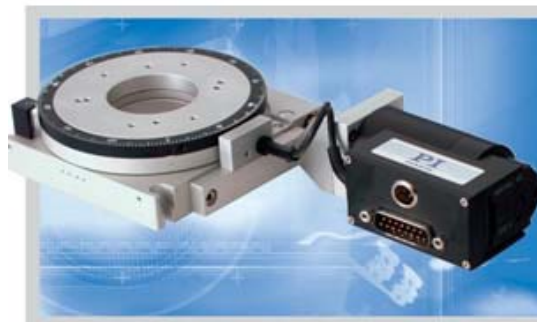

M-038.PD1 Rotation Stage



Custom M-038 with folded drive

Other Possible Crank motor: M-06X.DG Rotation stage

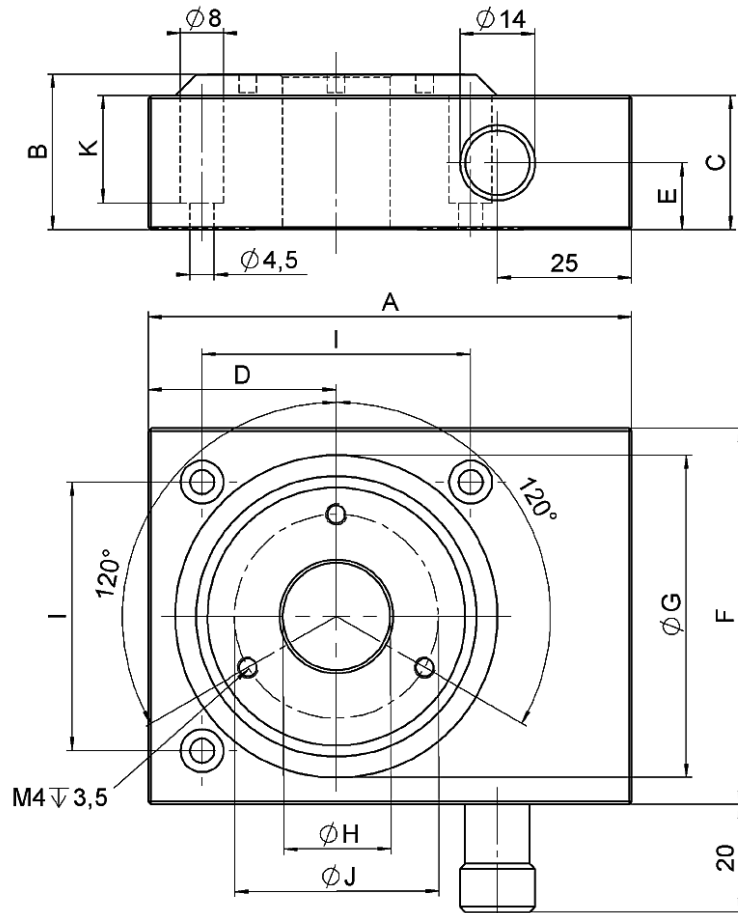

Dimensions	M-060.M0	M-061.M0	M-062.M0
A	90	130	150
B	29	34	42
C	25	30	38
D	35	55	65
E	12,5	15	21,5
F	70	110	130
G	60	100	120
H	20	35	45
I	50	90	110
J	38	50	60
K	20	20	28

Technical Data

Model	M-060.M0 / M-061.M0 / M-062.M0	M-060.PD / M-061.PD / M-062.PD	M-060.DG / M-061.DG / M-062.DG	M-060.2S / M-061.2S / M-062.2S	Units
Active axes	Rotation	Rotation	Rotation	Rotation	
Motion and positioning					
Rotation range	>360	>360	>360	>360	°
Integrated sensor	-	Rotary encoder	Rotary encoder		
Sensor resolution	-	4000	2000		Cts./rev.
Design resolution	-	32 (0.0018) / 17.5 (0.001) / 15 (0.0008)	2.1 (0.00012) / 1.2 (6.9 x 10 ⁻³) / 0.96 (5.5x10 ⁻³)	19.7 (0.0011) / 10.9 (0.00063) / 8.9 (0.00051)*	µrad (°)
Min. incremental motion	-	32 / 17.5 / 15	6.3 / 6 / 5	40 / 20 / 18*	µrad
Backlash	-	200 / 200 / 240	200 / 200 / 240	200 / 200 / 240	µrad
Unidirectional repeatability	-	50 / 50 / 60	50 / 50 / 60	50 / 50 / 60	µrad
Max. velocity	-	90	16 / 9 / 7.3	36 / 20 / 16	°/s
Mechanical properties					
Worm gear ratio	50:1 / 90:1 / 110:1	50:1 / 90:1 / 110:1	50:1 / 90:1 / 110:1	50:1 / 90:1 / 110:1	
Gear ratio	-	-	(28/12) ² : 1 ≈ 29.6:1	-	
Motor resolution	-	-	-	6400*	steps/rev.
Axial force	±500 / ±550 / ±650	±500 / ±550 / ±650	±500 / ±550 / ±650	±500 / ±550 / ±650	N
Max. torque θ_x, θ_y	±6 / ±6 / ±7	±6 / ±6 / ±7	±6 / ±6 / ±7	±6 / ±6 / ±7	Nm
Max. torque θ_z	±4 / ±6 / ±8	±4 / ±6 / ±8	±4 / ±6 / ±8	±4 / ±6 / ±8	Nm
Drive properties					
Motor type	-	ActiveDrive™ DC-Motor	DC-Motor, gearhead	2-phase Stepper-Motor**	
Operating voltage	-	24 (PWM)	12 differential	24	V
Electrical power	-	30	3	-	
Reference switch	Hall-effect	Hall-effect	Hall-effect	Hall-effect	
Miscellaneous					
Operating temperature range	-20 to +65	-20 to +65	-20 to +65	-20 to +65	°C
Material	Aluminum	Aluminum	Aluminum	Aluminum	
Mass	0.42 / 1.36 / 2.24	0.94 / 1.88 / 2.76	0.94 / 1.88 / 2.76	0.96 / 1.9 / 2.78	kg
Recommended controller/driver		C-863 single-axis C-843 PCI board, for up to 4 axes	C-863 single-axis (p. 4-114) C-843 PCI board (p. 4-120), for up to 4 axes	C-663 single-axis (p. 4-112)	

*with C-663 stepper-motor controller

**2-phase stepper-motor, 24 V chopper voltage, max. 0.8 A/phase, 400 full steps/rev



Potential Tip / Tilt Mirror

PI S-334 Miniature Piezo Fast Steering Tip/Tilt-Mirror
up to 120 mrad Deflection

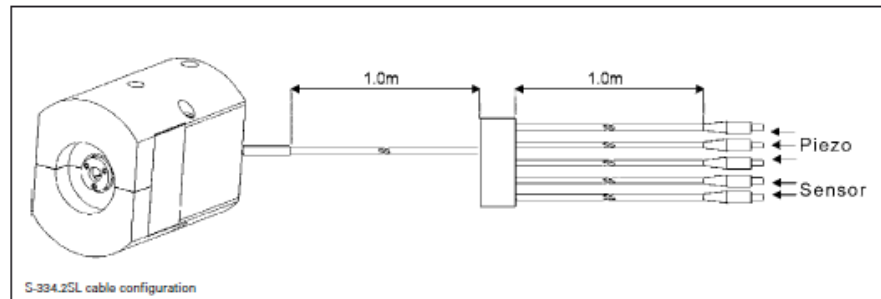
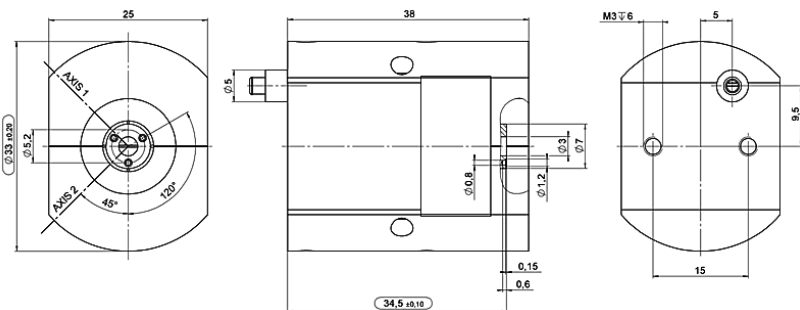

Technical Data

Model	S-334.2SL	S-334.2SD	Units	Tolerance
Active Axes	θ_x, θ_y	θ_x, θ_y		
Motion and positioning				
Integrated sensor	SGS	SGS		
*Open-loop tilt angle at -20 to +120 V	60	60	mrad	min. (+20%/-0%)
*Closed-loop tilt angle	50	50	mrad	
Open-loop resolution	0.5	0.5	μ rad	typ.
Closed-loop resolution	5	5	μ rad	typ.
Linearity	0.05	0.05	%	typ.
Repeatability	5	5	μ rad	typ.
Mechanical properties				
Resonant frequency under load (with standard mirrors)	1.0	1.0	kHz	$\pm 20\%$
Resonant frequency with 12.5 mm diam. x 2 mm glass mirror	0.8	0.8	kHz	$\pm 20\%$
Load capacity	0.2	0.2	N	Max.
Distance of pivot point to platform surface	6	6	mm	± 1 mm
Platform moment of inertia	1530	1530	$g \times mm^2$	$\pm 20\%$
Standard mirror (mounted)	diameter: 10 mm, thickness: 2 mm, BK7, $\lambda/5, R > 98\%$ ($\lambda = 500$ nm to 2 μ m)	diameter: 10 mm, thickness: 2 mm, BK7, $\lambda/5, R > 98\%$ ($\lambda = 500$ nm to 2 μ m)		
Drive properties				
Ceramic type	PICMA* P-885	PICMA* P-885		
Electrical capacitance	6	6	μ F	$\pm 20\%$
Miscellaneous				
Operating temperature range	-20 to 80	-20 to 80	$^{\circ}$ C	
Material casing	Titanium	Titanium		
Mass	0.065	0.065	kg	$\pm 5\%$
Cable length	2	2	m	± 10 mm
Sensor / voltage connection	LEMO connector	25-pin sub-D connector		
Recommended controller / amplifier	Modular piezo controller system E-500 (p. 2-144) with amplifier module E-503.00S (three channels) (p. 2-146) or 1 x E-505.00S and 2 x E-505 (high speed applications) (p. 2-147) and E-509 servo controller (p. 2-152) Open-loop: E-663 three channel amplifier (p. 2-136)	E-616 controller for tip/tilt mirror systems (p. 2-132)		

Potential Tip / Tilt Mirror

PI S-330-2XX Miniature Piezo Fast Steering Tip/Tilt-Mirror up to 120 mrad Deflection

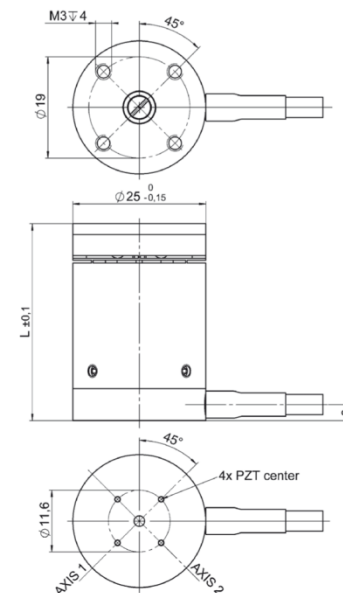

	L
S-330.2xx	37
S-330.4xx	55
S-330.8xx	91

Technical Data

Model	S-330.2SL	S-330.4SL	S-330.8SL	S-330.2SD S-330.4SD S-330.8SD	S-330.20L S-330.40L S-330.80L	Units	Tolerance
Active axes	Θ_x, Θ_y	Θ_x, Θ_y	Θ_x, Θ_y	Θ_x, Θ_y	Θ_x, Θ_y		
Motion and positioning							
Integrated sensor	SGS	SGS	SGS	SGS	-		
Open-loop tip/tilt angle, -20 to +120 V	3.5	7	15	as SL version	as SL version	mrad	min.
Closed-loop tip/tilt angle	2	5	10	as SL version	-	mrad	
Open-loop tip/tilt angle resolution	0.02	0.1	0.2	as SL version	as SL version	μ rad	typ.
Closed-loop tip/tilt resolution	0.05	0.25	0.5	as SL version	-	μ rad	typ.
Linearity in Θ_x, Θ_y	0.1	0.2	0.25	as SL version	-	%	typ.
Repeatability Θ_x, Θ_y	0.15	0.5	1	as SL version	-	μ rad	typ.
Mechanical properties							
Unloaded resonant frequency (Θ_x, Θ_y)	3.7	3.3	3.1	as SL version	as SL version	kHz	$\pm 20\%$
Resonant frequency loaded in Θ_x, Θ_y (with 25 x 8 mm glass mirror)	2.6	1.6	1.0	as SL version	as SL version	kHz	$\pm 20\%$
Distance of pivot point to platform surface	6	6	6	6	6	mm	± 1 mm
Platform moment of inertia	1530	1530	1530	1530	1530	g x mm ²	$\pm 20\%$
Drive properties							
Ceramic type	PICMA®	PICMA®	PICMA®	PICMA®	PICMA®		
Electrical capacitance	3/axis	6/axis	12.5/axis	as SL	as SL	μ F	$\pm 20\%$
Dynamic operating current coefficient	0.22/axis	0.4/axis	0.8/axis	as SL	as SL	μ A/Hz · mrad)	$\pm 20\%$
Miscellaneous							
Operating temperature range	-20 to 80	-20 to 80	-20 to 80	-20 to 80	-20 to 80	°C	
Material case	Stainless steel	Stainless steel	Stainless steel	Stainless steel	Stainless steel		
Material platform	Invar	Invar	Invar	Invar	Invar		
Mass	0.2	0.38	0.7	as SL version	as SL version	kg	$\pm 5\%$
Cable length	1.5	1.5	1.5	1.5	1.5	m	± 10 mm
Sensor / voltage connection	LEMO	LEMO	LEMO	Sub-D connector	LEMO		
Recommended controller / amplifier							

Versions with LEMO connector: modular piezo controller system E-500 (p. 2-142) with amplifier module E-503.00S (three channels) (p. 2-146)

or 1 x E-505.00S and 2 x E-505 (high speed applications) (p. 2-147) and E-509 controller (p. 2-152) (optional)

Open-loop: E-663 three channel amplifier (p. 2-136)

Versions with Sub-D connectors: E-616 servo controller for tip/tilt mirror systems (p. 2-132)

Ordering Information

S-330.2SL
High-Dynamics Piezo Tip/Tilt Platform, 2 mrad, SGS, LEMO Connector

S-330.2SD
High-Dynamics Piezo Tip/Tilt Platform, 2 mrad, SGS, Sub-D Connector

S-330.20L
High-Dynamics Piezo Tip/Tilt Platform, 2 mrad, Open-Loop, LEMO Connector

S-330.4SL
High-Dynamics Piezo Tip/Tilt Platform, 5 mrad, SGS, LEMO Connector

S-330.4SD
High-Dynamics Piezo Tip/Tilt Platform, 5 mrad, SGS, Sub-D Connector

S-330.40L
High-Dynamics Piezo Tip/Tilt Platform, 5 mrad, Open-Loop, LEMO Connector

S-330.8SL
High-Dynamics Piezo Tip/Tilt Platform, 10 mrad, SGS, LEMO Connector

S-330.8SD
High-Dynamics Piezo Tip/Tilt Platform, 10 mrad, SGS, Sub-D Connector

S-330.80L
High-Dynamics Piezo Tip/Tilt Platform, 10 mrad, Open-Loop, LEMO Connector

Preliminary Design Model

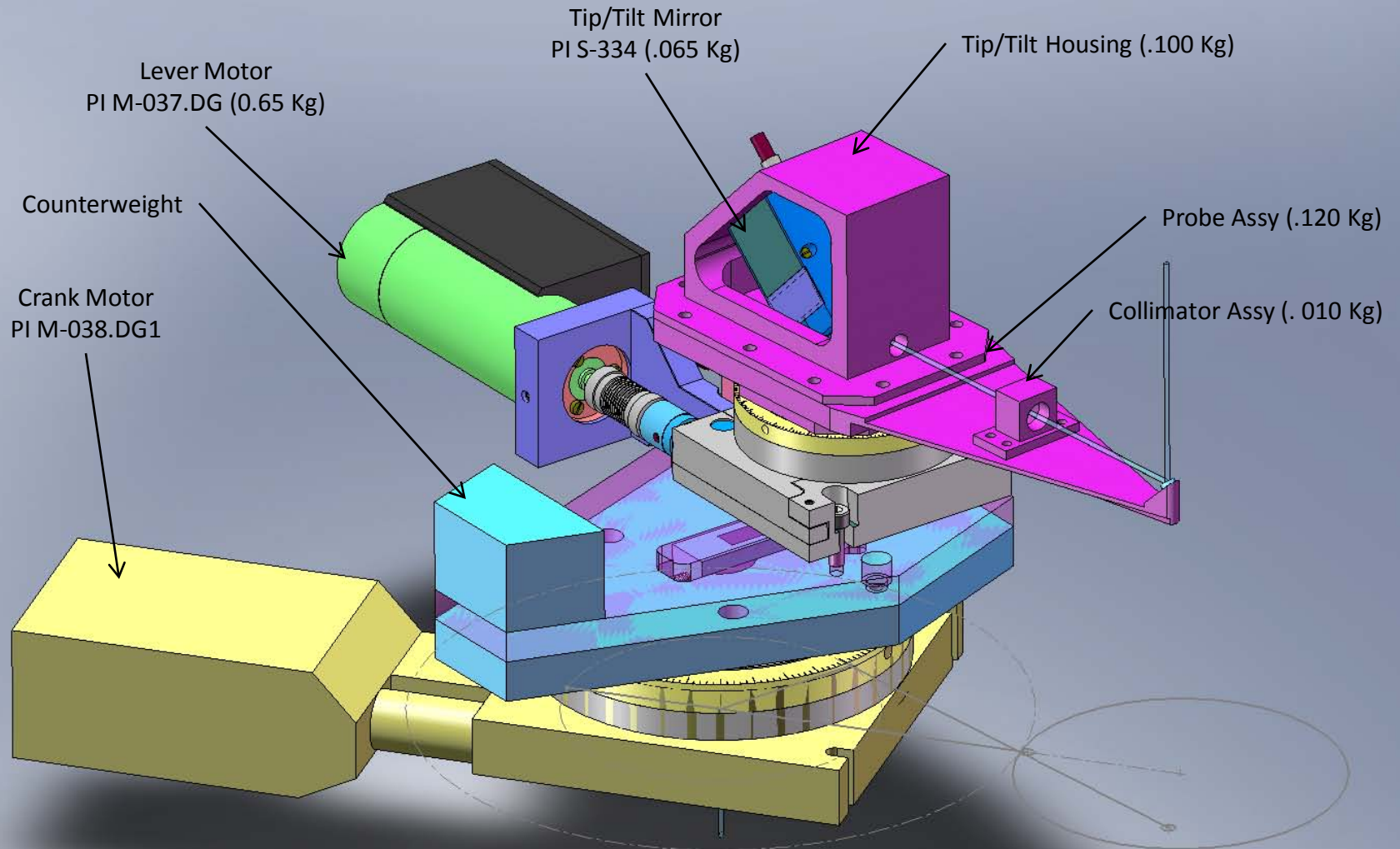

MaxTorque estimate at Crank axis:

Mass at Lever Axis: $0.65 + 0.065 + 100 + 120 + 0.01 = 1\text{Kg}$
 $1\text{Kg} (10\text{N})$ at $42\text{mm} = 10\text{ N} \times 0.042\text{m} = 0.42\text{Nm}$

Satisfies the CW & CCW Torque.

OSM Situation and orientation in its Assembly

The OSM is designed to be used on both LOWFS and LGS independently.

Each OSM is installed vertically and at 120° from each other.

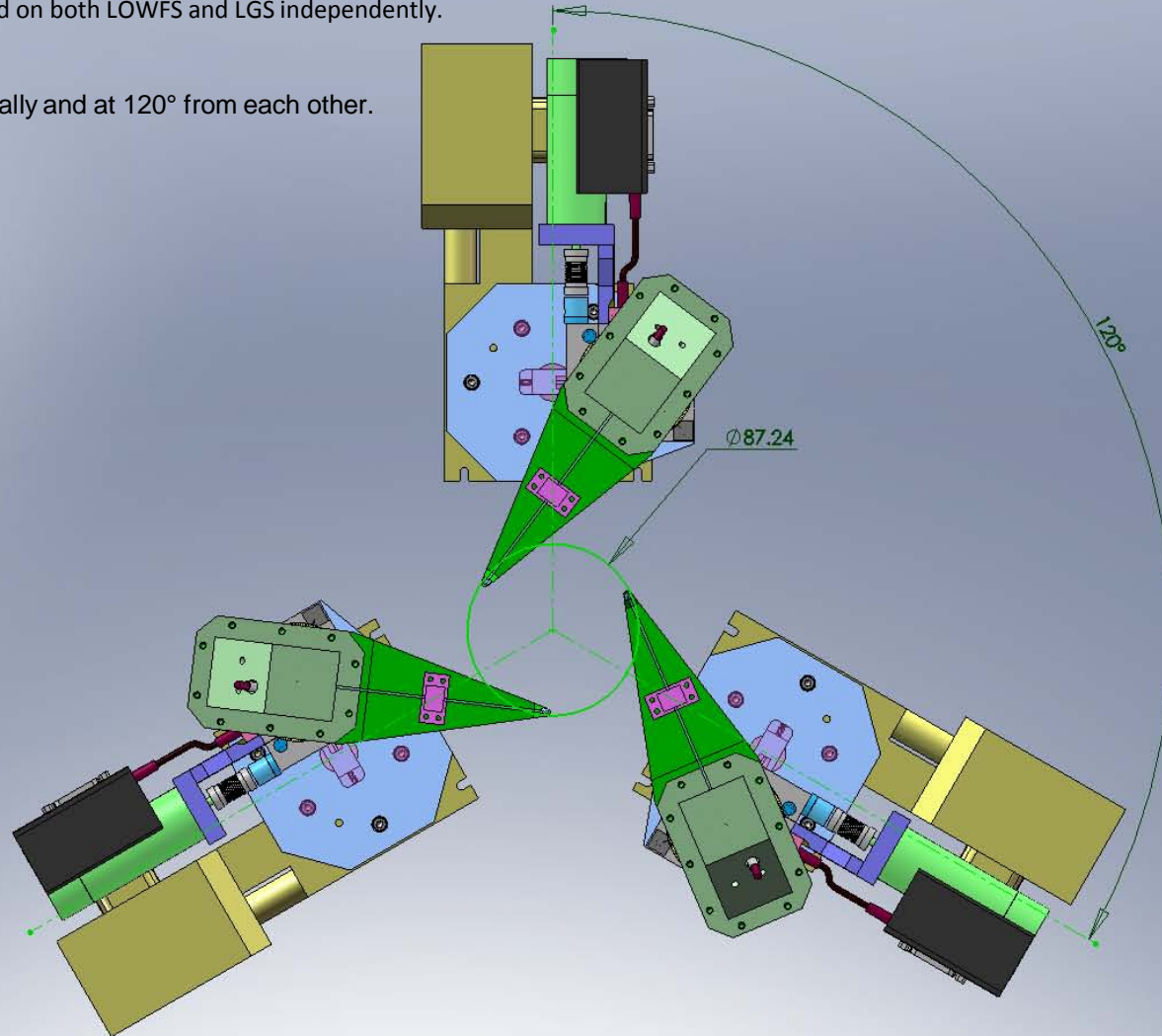

NOTE: This configuration seems to be challenging the LOWFS Pizza box model...

Lever Arm CG Location

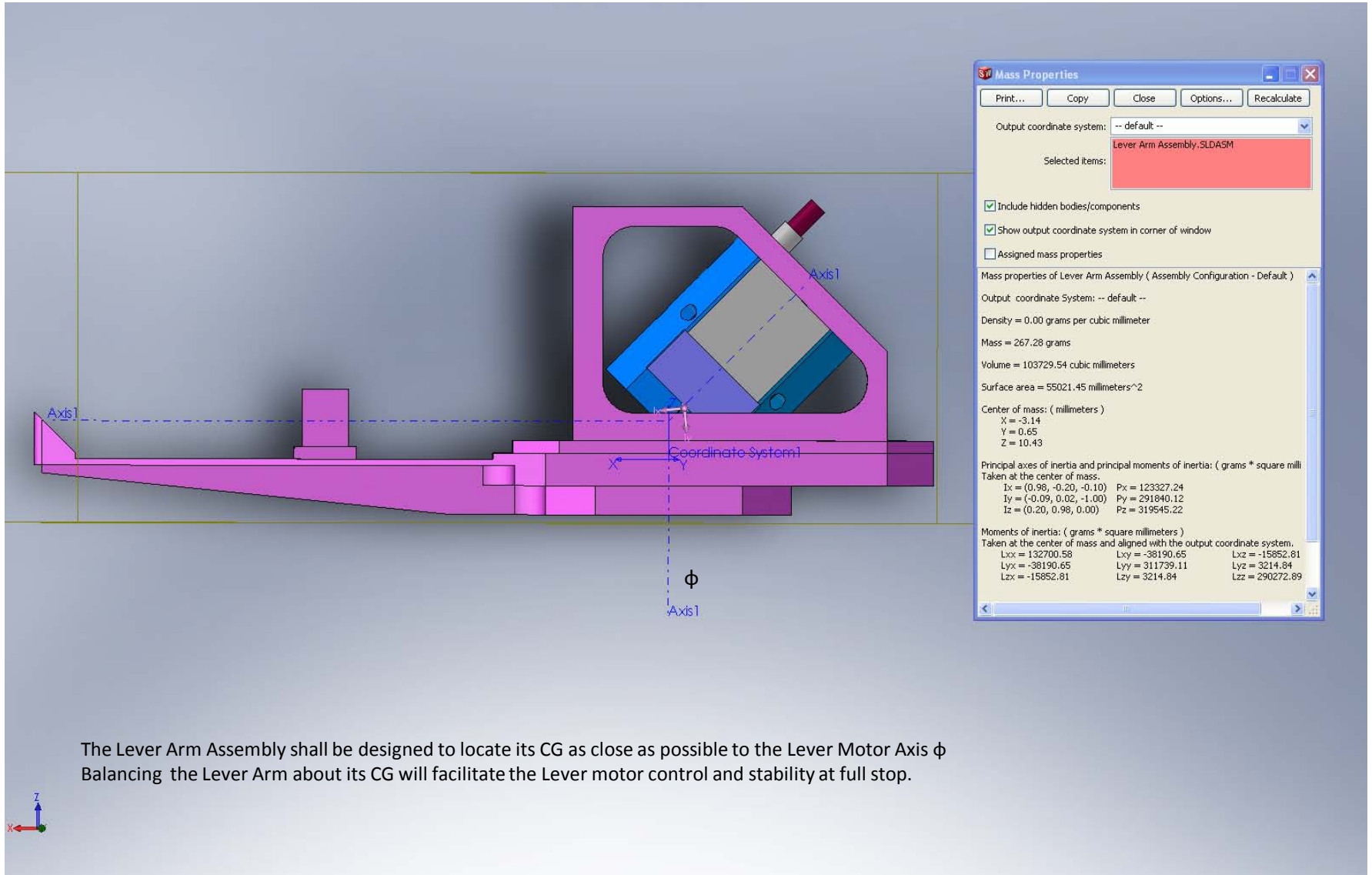

Anti-Collision System

NONCONTACT POSITION MEASURING SYSTEMS

SENSORS



Advanced family of high-precision position sensors

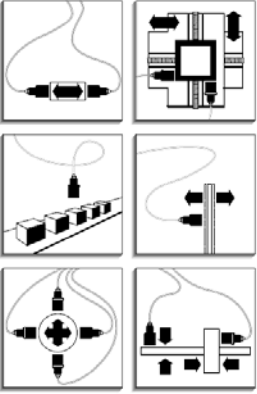

- FEATURES
- Ranges from 0.002 to 2.50 inches.
 - High speed analog and digital signal conditioning.
 - Rugged stainless steel and PEEK housings.
 - Dual coil and matched differential pairs minimize temperature, radiation and other environmental effects.
 - Sensors and cables rated to +400°F (+204°C).

Kaman Aerospace Memory & Measuring Systems

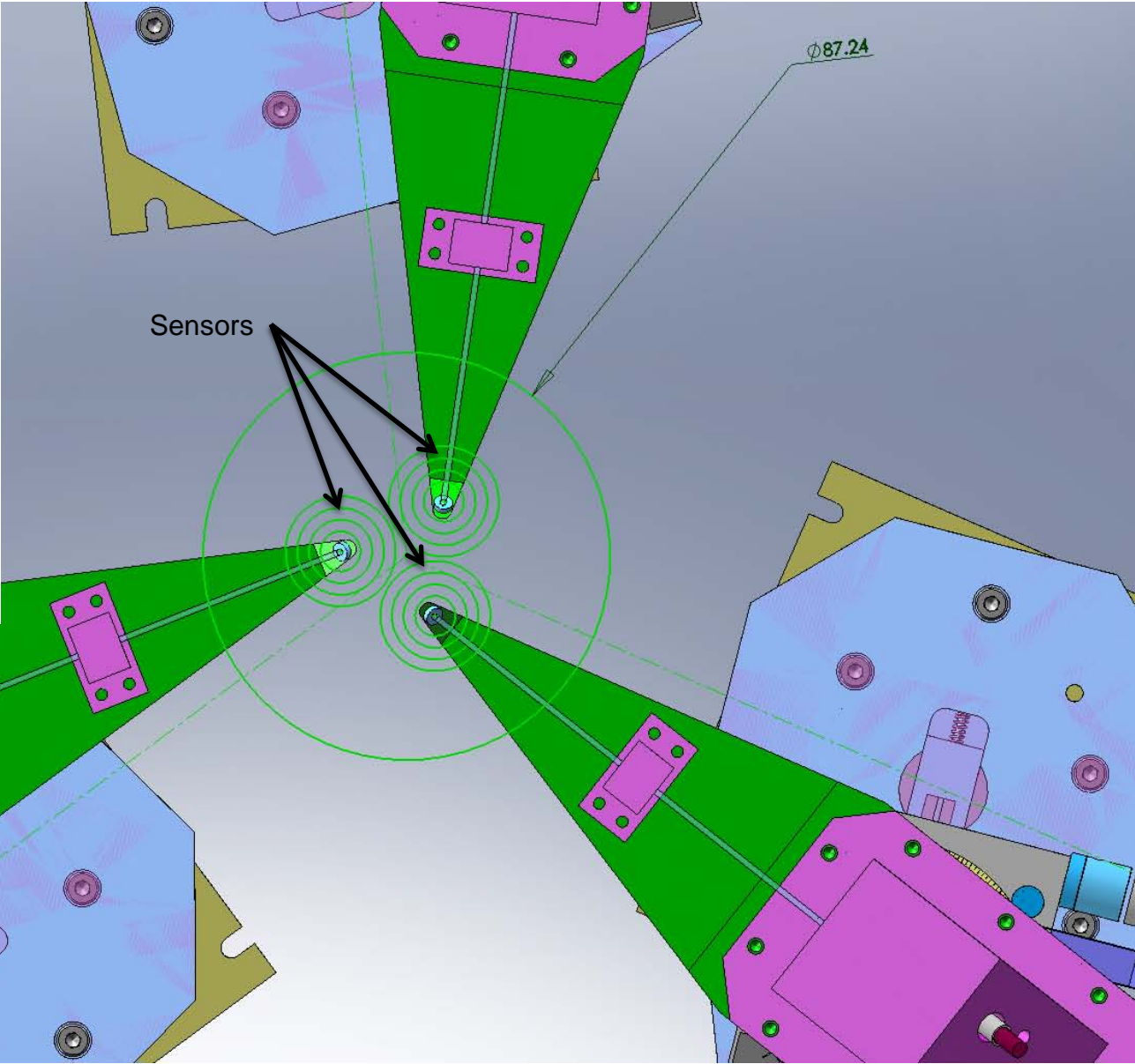

Remaining work to be done

- Choosing a probe Anti-collision System (Kaman?...)
- Analyze Tip/Tilt Mirror Vibrations and Impact on Probe stabilization.
- System rigidity Analysis
- System Integration within higher Assemblies
- Compare other motors and Tip / Tilt Mirrors.

Questions:

- Controller System: USB or RS232?
- Probe position Accuracy: 40 (KAON 562) or 70 mas (Contour)
- Minimum Incremental motion ?
- Max Wobble?
- Position Stability (5 mas / 3600 s) TBC
- TT Requirements (Deflection, response, resolution,...)

Remarks:

- Would Need Interface Solid model to verify dimensional assumptions?

Rejected Lever Motors



435 Route 206 • P.O.Box 366
Newton NJ 07860-0366

SALES: (973) 579-7227
FAX: (973) 300-3600
www.thorlabs.com

Motorized Rotation Stage

- ▶ Continuous 360° Motorized Rotation With 1arcsec Resolution
- ▶ Houses Ø1" Optics up to 0.50" Thick
- ▶ Compatible With Our SM1 Lens Tube Accessories



Overview

Features

- 1° Graduations on Main Dial
- Compact Design (23 mm Deep)
- Precision Home Limit Switch
- Post Mountable
- Ideal for SM1 (1.035"-40) Compatible Accessories
- Directly Accepts Ø1" Optics up to 0.50" (12.5 mm) Thick
- Fully Compatible with Our SM1 Lens Tube (1.035"-40 Thread) Accessories

Specification	Value
Bidirectional Repeatability	±0.1°
Backlash	±0.3°
Max Rotation Velocity	25 deg/sec
Horizontal On-Axis Load Capacity	1.5 kg
Vertical On-Axis Load Capacity	0.5 kg
Min Achievable Incremental Motion	25 arcsec
Min Repeatable Incremental Motion	0.03°
Absolute On-Axis Accuracy	0.1%
Max Percentage Accuracy	0.08%
Home Location Accuracy	±0.2°
Range	360° Continuous

With a depth of only 23 mm (0.9"), the PRM1Z8 is a small, compact, motorized rotation stage and mount that accepts Ø1" optics and is based on our popular PRM1 Rotation Mount. Rotation is driven via a DC servo motor that is equipped with a 67:1 gearbox and a rotary encoder for accurate closed-loop position control. The user can measure the angular displacement by using the Vernier dial in conjunction with the graduation marks that are marked on the rotating plate in 1° increments. The precision DC motor actuator provides 1 arcsecond of resolution over the entire 360° of rotation. This rotation stage/mount is also equipped with a precision home limit switch to facilitate automated rotation to the zero datum position, thus ensuring absolute angular positioning thereafter. The limit switch is designed to allow continuous rotation of the stage over multiple 360° cycles.

The [TDC0001 DC Servo Controller](#) is the ideal companion for achieving smooth, continuous motion that can be automated via the software interface. The stage/mount and controller are sold together below with the item number PRM1Z8E and PRM1MZ8E.

Normally the PRM1Z8 is mounted horizontally. The stage can be fixed directly to the work surface using the counter-bored holes in the main body. For complete flexibility, the stage/mount can be used vertically on a standard Ø1/2" post and has an option to mount in a vertical inclined orientation. When in the vertical orientation, the reduced thickness of the stage is extremely beneficial for optical path applications where space is limited.

The PRM1Z8 is supplied with 19.6' (0.5 m) of cable. An 8 ft (2.5 m) extension cable (PAA632) is available separately.

The rotating platform features several accessories. The central aperture has a standard SM1 internal thread, for

Rejected Crank Motors



435 Route 206 • P.O. Box 366
Newton NJ 07860-0366

SALES: (973) 579-7227
FAX: (973) 300-3600
www.thorlabs.com

360 Degree Continuous Rotation Stage with Stepper Motor Actuator

- ▶ 1 arcsec Microsteps
- ▶ 50 kg Load Capacity
- ▶ Compatible with LNR and NRT Series Linear Translation Stages

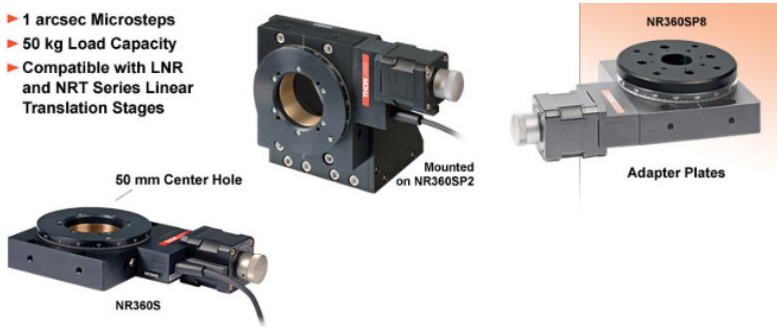

Overview

Features

- Resolution Better than 1 arcsec
- Manual Control of the Rotating Carriage
- High Capacity, 50kg Maximum Axial Load
- Preloaded Worm Gear Drive Mechanism with Minimal Backlash
- Origin Indicating Switch Every 360°
- Mounting Options: Four 1/4" (M6) Countersunk Holes and Nine M6 Tapped Holes

The NR series rotation stage provides arc-second resolution when driven from a micro-stepping stepper motor controller, such as the BSC100 Series. The low profile design has a height of just 55 mm due to the use of two compact precision bearings. The rotating carriage of the stage features continuous rotation and can support loads up to 50 kg. The 50 mm clear aperture through the center of the rotation stage allows the stage to be used in applications where the optical axis and rotation axis are parallel. The frame of the stage is made from aluminum and has four 1/4" (M6) countersunk holes that allow the stage to be secured to a translation stage or optical table using one of the adapter plates presented below. In addition, 9 M6 tapped mounting holes are located on the side of the frame to provide additional mounting options. A worm gear assembly transfers the rotary motion of the stepper motor into rotary motion of the carriage. The mechanical reduction in this gear assembly provides one revolution of the carriage for every 66 turns of the stepper motor.

We encourage you to review the tabs above for detailed specifications of the NR360S and the recommended Stepper Motor Controller, the BSC100 Series. Please note that Thorlabs offers bottom mounting adapter plates and brackets to secure the NR360S as well as several types of rotating adapter plates; these items are featured below with more detailed product descriptions.

NR360S

Specs

Specification	Value	Motor Specs	
Travel	360° Continuous Rotation	Step Angle	1.8°
On Axis Load Capacity	110 lbs (50 kg)	Rated Phase Current	1 A
Drive Mechanism	Worm Drive	Phase Resistance	4.6Ω
Limit Switches	Reference Signal Every 360°	Phase Inductance	0.6 mH
Motor Type	2 Phase Stepper	Holding Torque	23.1 N-cm
Theoretical Resolution	1 arcsec (If Used with BSC101)	Detent Torque	1.7 N-cm
Speed Range	15°/sec (If Used with BSC101)	Rotor Inertia	32 g-cm ²
Recommended Controller	BSC101		
Weight (Actuator)	3.11 lbs (1.4 kg)		