

NGAO OSM

Design Study

Alex Delacroix

06/15/2009

Conceptual design and operation

The $\varnothing 5''$ (3.635 mm) probe covers the entire $\varnothing 120''$ (87.24 mm) Field of View.

The 2 degrees of freedom probe arm consists of 2 individual arms: A crank arm and a lever arm, driven by 2 corresponding rotation motors: The crank and lever motors.

Any position in the OSM field of view can be acquired by calculating appropriate values for theta and phi, noting that due to a mirror reflection there are always 2 possible solutions.

The crank motor is secured to the Sensor and rotates the crank arm, precisely about the rotation axis of the crank motor referred to as the theta axis. The lever arm motor provides the necessary second degree of freedom by rotating the lever arm and all associated optics, about the phi axis.

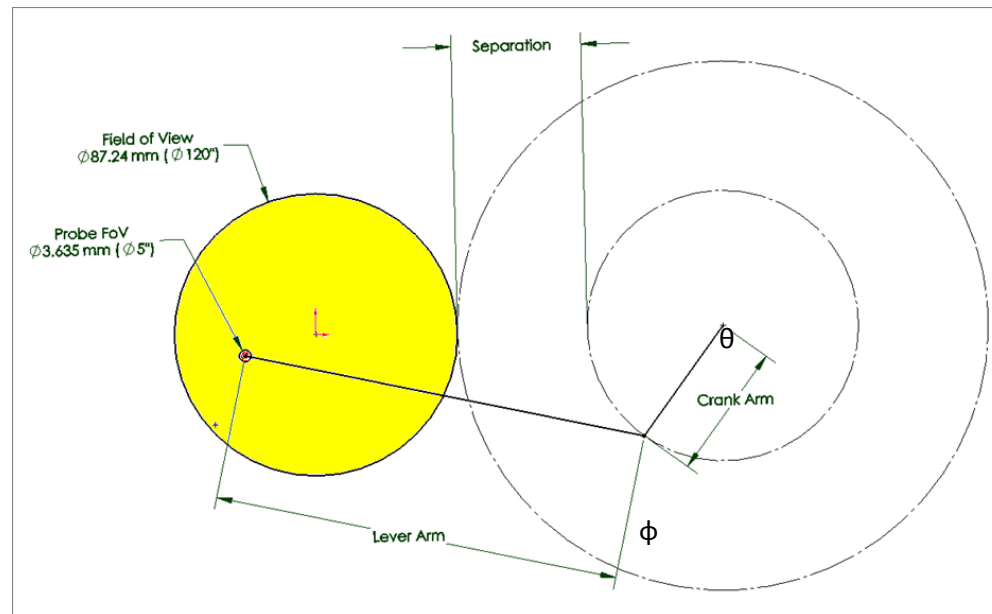

Basic Design requirements:

Mechanism Type:	ϕ/θ
Patrolled Field:	$\varnothing 120''$ (87.24mm)
Probe FoV:	$\varnothing 5''$ (3.635mm)
Acquisition accuracy:	40 mas (30 μ m)
Stability:	5 mas / 3600s (1 μ m)
Position knowledge:	< 1 μ m (TBC)
Minimum Incremental motion:	TBD
Operating Temperature:	-10°C +/- 0.3

Note: Separation is a distance determined by the Lever Arm motor envelope.

Position Accuracy

Probe Position within the field shall be measured according to the level of desired accuracy: Direct or indirect.

Indirect measurement:

Total Position Accuracy of 30 μ m at the furthest position across the 144mm field requires a minimum crank rotation accuracy of:

$$\sin \alpha = 30\mu\text{m} / 144 \text{ mm} \rightarrow \alpha = 0.012^\circ = .012 \pi / 180 = .00021 \text{ rad} = 210 \mu\text{rad}$$

And the 100 mm lever arm motor is 60 % longer than the 40mm Crank arm

Crank motor rotation accuracy: 210 μ rad x 60% = 126 μ rad

Lever motor rotation accuracy: 210 μ rad x 40% = 84 μ rad

Arms Size Equation

Arm fully extended Equation:

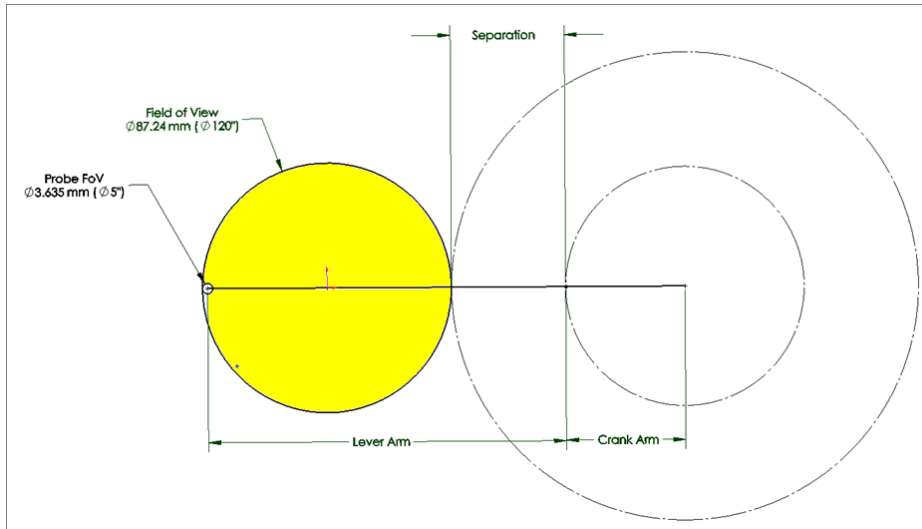

$$\text{Lever Arm} + \text{Crank Arm} + \text{Probe} = \text{Fov} + \text{Separation} + \text{Crank Arm}$$

$$\text{Lever Arm} + 1.8175 = 87.24 + 40$$

$$\rightarrow \text{Lever Arm} = 125.42 \text{ mm}$$

Arm fully retracted Equation:

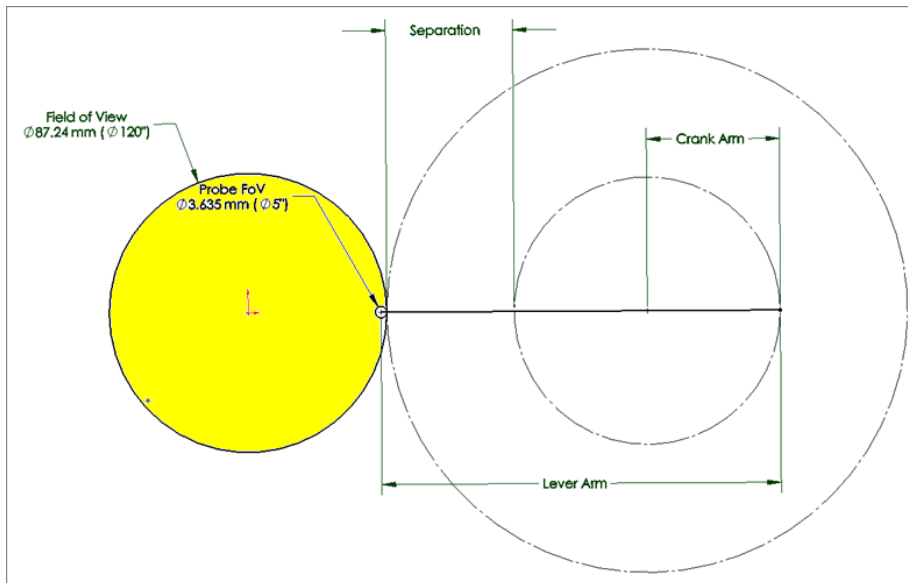

$$\text{Lever Arm} - \text{Crank Arm} = \text{Separation} + \text{Crank Arm} + \text{Probe}$$

$$\rightarrow \text{Crank Arm} = 41.30 \text{ mm}$$

Servo Motors Vs Stepper Motors

Motion Characteristics	Servo Motors	Stepper Motors
High Torque, Low Speed	Can be considered if cost/ complexity is not an issue.	Continuous duty applications requiring high torque and low speed.
High Torque and high speed (>2000 rpm)	<p>Continuous duty applications requiring high torque and high speed.</p> <p>DC servomotor can deliver greater continuous shaft power at high speeds compared to steppers. High speed up to 12000 rpm is possible.</p> <p>AC servo motors can handle higher current surges compared to DC servos.</p> <p>Can get lot stronger AC servo compared to either DC servo or DC stepper.</p>	<p>If speeds are less than 2000 rpm stepper may be economical.</p> <p>Stepper becomes bulky at high torque.</p>
Short, Rapid Repetitive Moves	Use servo if need high dynamic requirements.	Stepper will offer more economic solution when requirements are more modest.
Positioning Applications	Servo can handle effectively when load is mostly inertia instead of friction. The ability to overdrive servo motor in intermittent duty allows a smaller motor to be used. If positioning is critical in micron level use servo.	Use stepper motor if torque is lower than 500 oz-in, less 2000 rpm, low to medium acceleration rates.
Applications in Hazardous Environments	Use brushless servo motor.	Use step motor.
Low Speed, High Smoothness	Use DC servo.	Use microstepping.
Control Method	Closed loop.	Preferred to be used in open loop applications.

Potential Lever Motor

PI M-037.DG Rotation stage

M-037 rotation stages are equipped with ultra-precise worm gear drives allowing unlimited rotation in either direction. An integrated spring preload eliminates backlash. Double-row ball bearings allow zero backlash, high load capacity and extremely low wobble.

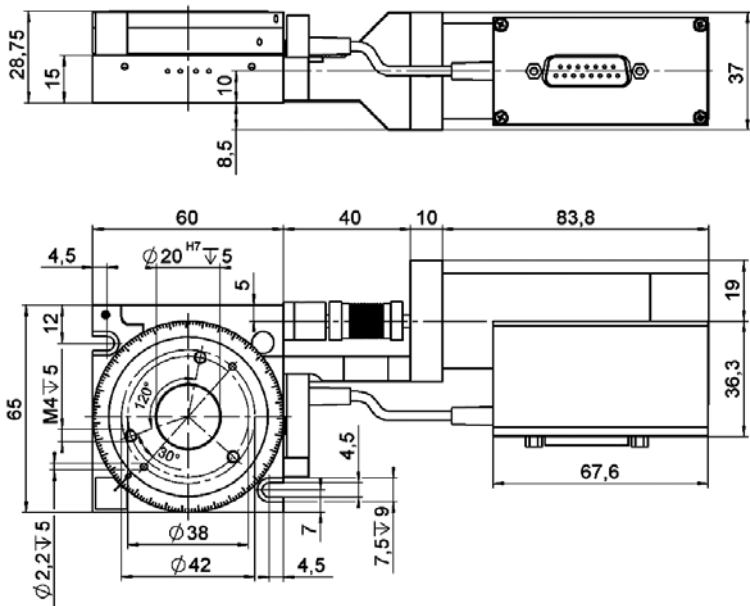

Technical Data

Model	M-037.00	M-037.DG	M-037.PD	M-037.2S	
Active axes	Rotation	Rotation	Rotation	Rotation	
Motion and positioning					
Rotation range	>360	>360	>360	>360	°
Integrated sensor	-	Rotary encoder	Rotary encoder	-	
Sensor resolution	-	2000	4000	-	cts./rev.
Design resolution	-	0.59 (34 x 10 ⁻⁴)	3.75 (0.0005)	5.45* (0.00031)	µrad (°)
Min. incremental motion	-	3.5	27	21	µrad
Backlash	-	200	200	200	µrad
Unidirectional repeatability	-	30	30	30	µrad
Wobble	<150	<150	<150	<150	µrad
Max. velocity	-	6	45	10	°/s
Mechanical properties					
Worm gear ratio	180:1	180:1	180:1	180:1	
Gear ratio	-	(28/12)* = 29.6:1	-	-	
Motor resolution	-	-	-	6400*	steps/rev.
Load capacity/axial force, self-locking	±300	±300	±300	±300	N
Max. torque (θ ₁ , θ ₂)	±3	±3	±3	±3	Nm
Max. torque clockwise (θ ₂)	1	1	1	1	Nm
Max. torque counter clockwise (θ ₂)	0.5	0.5	0.5	0.5	Nm
Drive properties					
Motor type	-	DC motor, gearhead	ActiveDrive™ DC Motor	2-phase stepper motor*	
Operating voltage	-	0 to ±12	24 (PWM)	24	V
Electrical power	-	3	30	-	W
Reference switch	-	Hall-effect	Hall-effect	Hall-effect	
Miscellaneous					
Operating temperature range	-20 to +65	-20 to +65	20 to +65	-20 to +65	°C
Material	Aluminum	Aluminum	Aluminum	Aluminum	
Mass	0.3	0.65	0.62	0.64	kg
Recommended controller/driver	-	C-863 (single-axis) C-843 PCI-Karte (for up to 4 axes)	C-863 (single-axis, p. 4-114) C-843 PCI-Karte (p. 4-120) (for up to 4 axes)	C-663 (single-axis, p. 4-112)	

incl. motor cable, 3 m, sub-D connector 15-pin

*2-phase stepper motor, 24 V chopper voltage, max. 0.8 A/phase, 400 full steps/rev., motor resolution with C-663 stepper motor controller



M-037.DG rotation stage with DC Motor and gearhead

Potential Crank Motor

PI M-038.DG Rotation stage

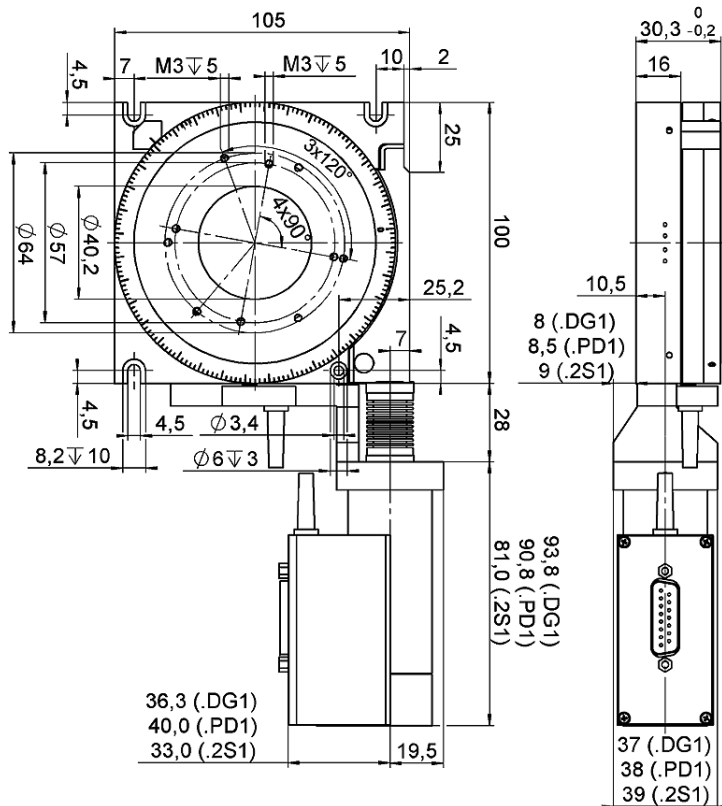

Technical Data

Model	M-038.001	M-038.DG1	M-038.PD1	M-038.2S1	Units
Active axes	Rotation	Rotation	Rotation	Rotation	
Motion and positioning					
Rotation range	>360°	>360°	>360°	>360°	
Integrated sensor	-	Rotary encoder	Rotary encoder	-	
Sensor resolution	-	2000	4000	-	steps/rev.
Design resolution	-	0.60 (35 x 10 ⁻⁴)	8.95 (0.0005)	5.58* (0.00032)	µrad (°)
Min. incremental motion	-	3.5	27	21	µrad
Backlash	-	200	200	200	µrad
Unidirectional repeatability	-	20	20	20	µrad
Wobble	<75	<75	<75	<75	µrad
Max. velocity	-	6	90	10	°/s
Mechanical properties					
Worm gear ratio	176:1	176:1	176:1	176:1	
Gear ratio	-	2401:81 = 29.6:1	-	-	
Motor resolution	-	-	-	6400*	steps/rev.
Max. load/axial force	±400	±400	±400	±400	N
Maximum torque (θ _x , θ _y)	±6	±6	±6	±6	
Maximum torque CW**	2	2	2	2	Nm
Maximum torque CCW**	0.8	0.8	0.8	0.8	Nm
Drive properties					
Motor type	-	DC Motor, gearhead	ActiveDrive™ DC Motor	2-phase stepper motor*	
Electrical power	-	3	30		W
Reference switch	-	Hall-effect	Hall-effect	Hall-effect	
Miscellaneous					
Operating voltage	-	12 V differential	24 (PWM)	24	V
Operating temperature range	-20 to +65	-20 to +65	-20 to +65	-20 to +65	°C
Material	Aluminum	Aluminum	Aluminum	Aluminum	
Mass	0.9	1.25	1.35	1.25	kg
Recommended controller/driver		C-863 (single-axis) C-843 PCI board (for up to 4 axes)	C-863 (single-axis, p. 4-114) C-843 PCI board (p. 4-120) (for up to 4 axes)	C-663 (single-axis, p. 4-112)	

*2-phase stepper motor, 24 V chopper voltage, max. 0.8 A/phase, 400 full steps/rev., motor resolution with C-663 stepper motor controller

**CW: clockwise; CCW: counter-clockwise



M-038.PD1 Rotation Stage



Custom M-038 with folded drive

Other Possible Crank motor: M-06X.DG Rotation stage

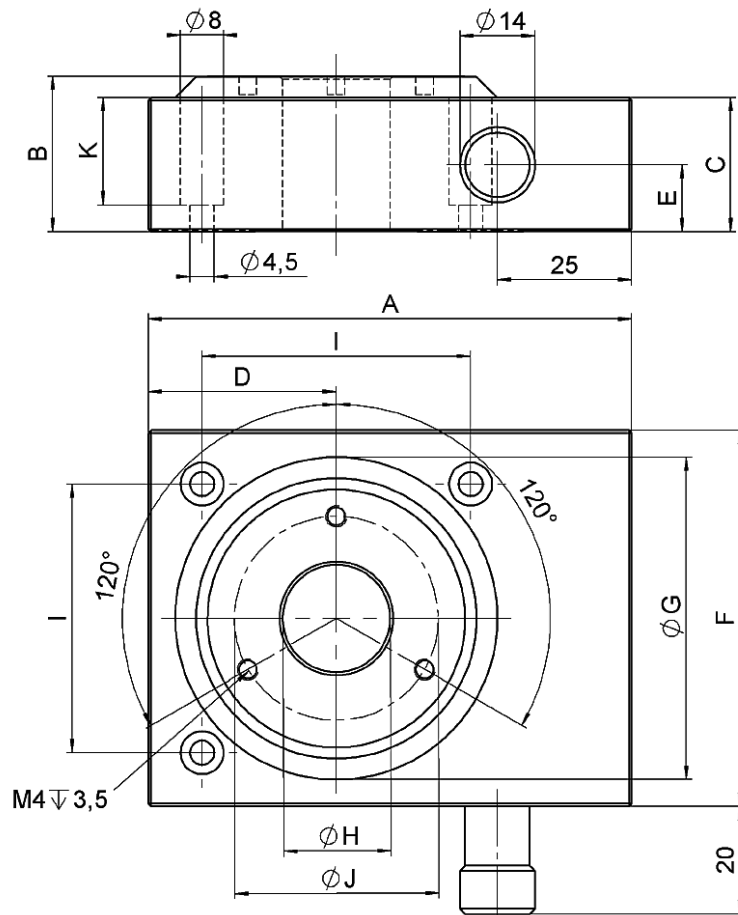

Dimensions	M-060.M0	M-061.M0	M-062.M0
A	90	130	150
B	29	34	42
C	25	30	38
D	35	55	65
E	12,5	15	21,5
F	70	110	130
G	60	100	120
H	20	35	45
I	50	90	110
J	38	50	60
K	20	20	28

Technical Data

Model	M-060.M0 / M-061.M0 / M-062.M0	M-060.PD / M-061.PD / M-062.PD	M-060.DG / M-061.DG / M-062.DG	M-060.2S / M-061.2S / M-062.2S	Units
Active axes	Rotation	Rotation	Rotation	Rotation	
Motion and positioning					
Rotation range	>360	>360	>360	>360	°
Integrated sensor	-	Rotary encoder	Rotary encoder		
Sensor resolution	-	4000	2000		Cts./rev.
Design resolution	-	32 (0.0018) / 17.5 (0.001) / 15 (0.0008)	2.1 (0.00012) / 1.2 (6.9 x 10 ⁻³) / 0.96 (5.5x10 ⁻³)	19.7 (0.0011) / 10.9 (0.00063) / 8.9 (0.00051)*	µrad (°)
Min. incremental motion	-	32 / 17.5 / 15	6.3 / 6 / 5	40 / 20 / 18*	µrad
Backlash	-	200 / 200 / 240	200 / 200 / 240	200 / 200 / 240	µrad
Unidirectional repeatability	-	50 / 50 / 60	50 / 50 / 60	50 / 50 / 60	µrad
Max. velocity	-	90	16 / 9 / 7.3	36 / 20 / 16	°/s
Mechanical properties					
Worm gear ratio	50:1 / 90:1 / 110:1	50:1 / 90:1 / 110:1	50:1 / 90:1 / 110:1	50:1 / 90:1 / 110:1	
Gear ratio	-	-	(28/12) ² : 1 ≈ 29.6:1	-	
Motor resolution	-	-	-	6400*	steps/rev.
Axial force	±500 / ±550 / ±650	±500 / ±550 / ±650	±500 / ±550 / ±650	±500 / ±550 / ±650	N
Max. torque θ_x, θ_y	±6 / ±6 / ±7	±6 / ±6 / ±7	±6 / ±6 / ±7	±6 / ±6 / ±7	Nm
Max. torque θ_z	±4 / ±6 / ±8	±4 / ±6 / ±8	±4 / ±6 / ±8	±4 / ±6 / ±8	Nm
Drive properties					
Motor type	-	ActiveDrive™ DC-Motor	DC-Motor, gearhead	2-phase Stepper-Motor**	
Operating voltage	-	24 (PWM)	12 differential	24	V
Electrical power	-	30	3	-	
Reference switch	Hall-effect	Hall-effect	Hall-effect	Hall-effect	
Miscellaneous					
Operating temperature range	-20 to +65	-20 to +65	-20 to +65	-20 to +65	°C
Material	Aluminum	Aluminum	Aluminum	Aluminum	
Mass	0.42 / 1.36 / 2.24	0.94 / 1.88 / 2.76	0.94 / 1.88 / 2.76	0.96 / 1.9 / 2.78	kg
Recommended controller/driver		C-863 single-axis C-843 PCI board, for up to 4 axes	C-863 single-axis (p. 4-114) C-843 PCI board (p. 4-120), for up to 4 axes	C-663 single-axis (p. 4-112)	

*with C-663 stepper-motor controller

**2-phase stepper-motor, 24 V chopper voltage, max. 0.8 A/phase, 400 full steps/rev



Potential Tip / Tilt Mirror

PI S-334 Miniature Piezo Fast Steering Tip/Tilt-Mirror
up to 120 mrad Deflection

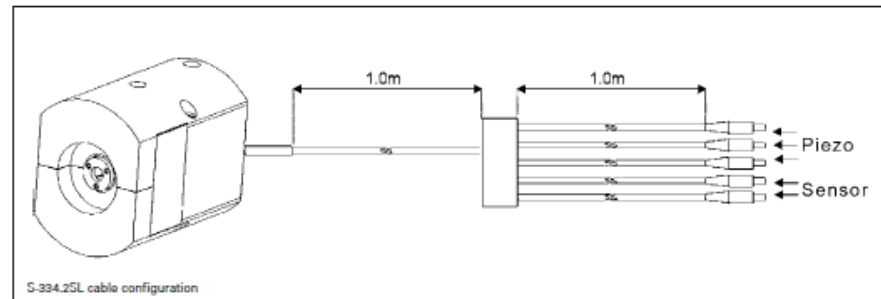
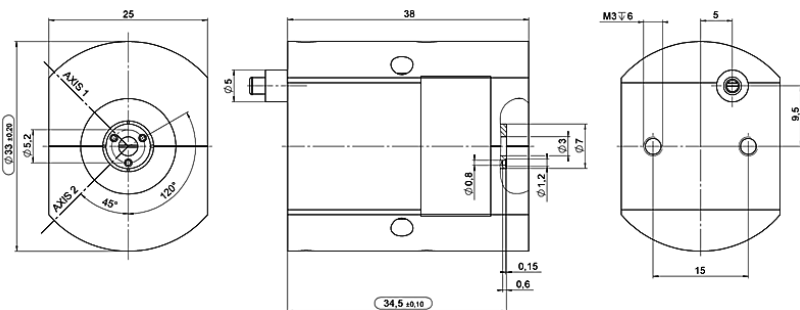

Technical Data

Model	S-334.2SL	S-334.2SD	Units	Tolerance
Active Axes	θ_x, θ_y	θ_x, θ_y		
Motion and positioning				
Integrated sensor	SGS	SGS		
*Open-loop tilt angle at -20 to +120 V	60	60	mrad	min. (+20%/-0%)
*Closed-loop tilt angle	50	50	mrad	
Open-loop resolution	0.5	0.5	μ rad	typ.
Closed-loop resolution	5	5	μ rad	typ.
Linearity	0.05	0.05	%	typ.
Repeatability	5	5	μ rad	typ.
Mechanical properties				
Resonant frequency under load (with standard mirrors)	1.0	1.0	kHz	$\pm 20\%$
Resonant frequency with 12.5 mm diam. x 2 mm glass mirror	0.8	0.8	kHz	$\pm 20\%$
Load capacity	0.2	0.2	N	Max.
Distance of pivot point to platform surface	6	6	mm	± 1 mm
Platform moment of inertia Standard mirror (mounted)	1530	1530	$g \times mm^2$	$\pm 20\%$
	diameter: 10 mm, thickness: 2 mm, BK7, $\lambda/5, R > 98\%$ ($\lambda = 500$ nm to 2 μ m)	diameter: 10 mm, thickness: 2 mm, BK7, $\lambda/5, R > 98\%$ ($\lambda = 500$ nm to 2 μ m)		
Drive properties				
Ceramic type	PICMA* P-885	PICMA* P-885		
Electrical capacitance	6	6	μ F	$\pm 20\%$
Miscellaneous				
Operating temperature range	-20 to 80	-20 to 80	$^{\circ}$ C	
Material casing	Titanium	Titanium		
Mass	0.065	0.065	kg	$\pm 5\%$
Cable length	2	2	m	± 10 mm
Sensor / voltage connection	LEMO connector	25-pin sub-D connector		
Recommended controller / amplifier	Modular piezo controller system E-500 (p. 2-144) with amplifier module E-503.00S (three channels) (p. 2-146) or 1 x E-505.00S and 2 x E-505 (high speed applications) (p. 2-147) and E-509 servo controller (p. 2-152) Open-loop: E-663 three channel amplifier (p. 2-136)	E-616 controller for tip/tilt mirror systems (p. 2-132)		

Preliminary Design Model

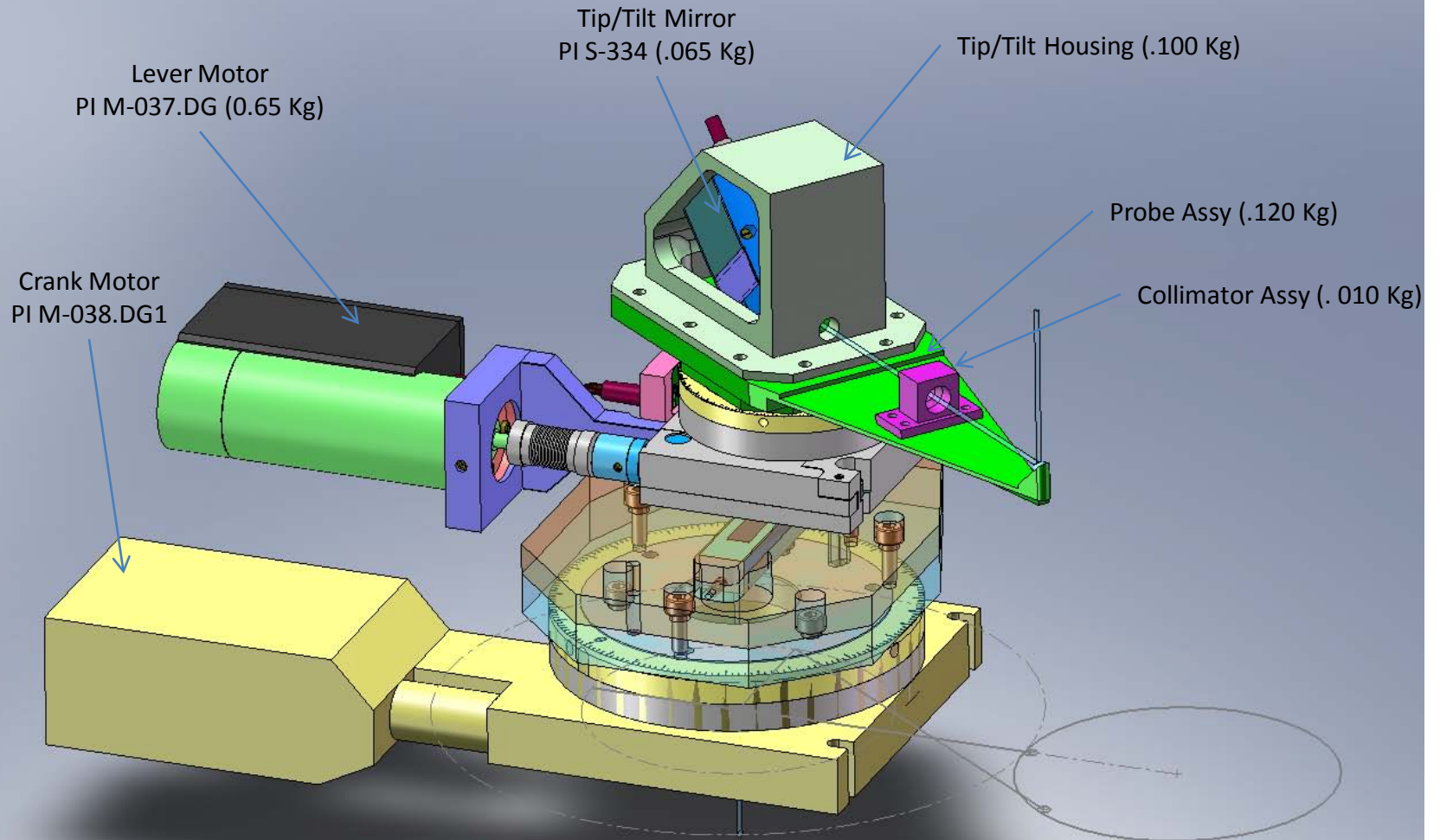

MaxTorque estimate at Crank axis:

Mass at Lever Axis: $0.65 + 0.065 + 100 + 120 + 0.01 = 1\text{Kg}$

1Kg (10N) at 42mm = $10\text{ N} \times 0.042\text{m} = 0.42\text{Nm}$

Satisfy the CW Torque Only

The motor would have to be positioned to fight gravity in the CW direction only.

OSM Situation and orientation in its Assembly

The OSM is designed to be used on both LOWFS and LGS independently.

Each OSM is installed vertically and at 120° from each other.

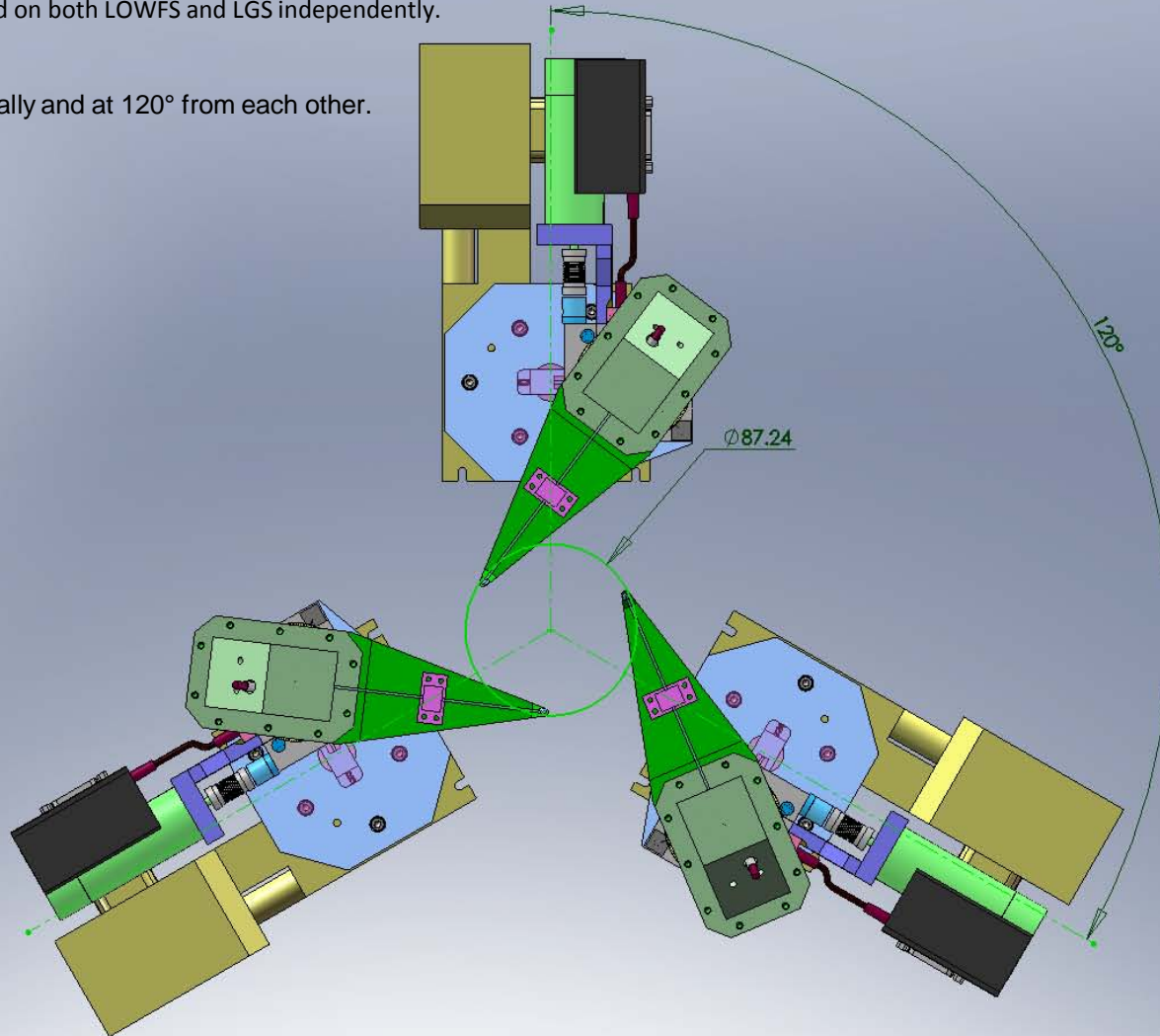

NOTE: This configuration seems to be challenging the LOWFS Pizza box model...

Lever Arm CG Location

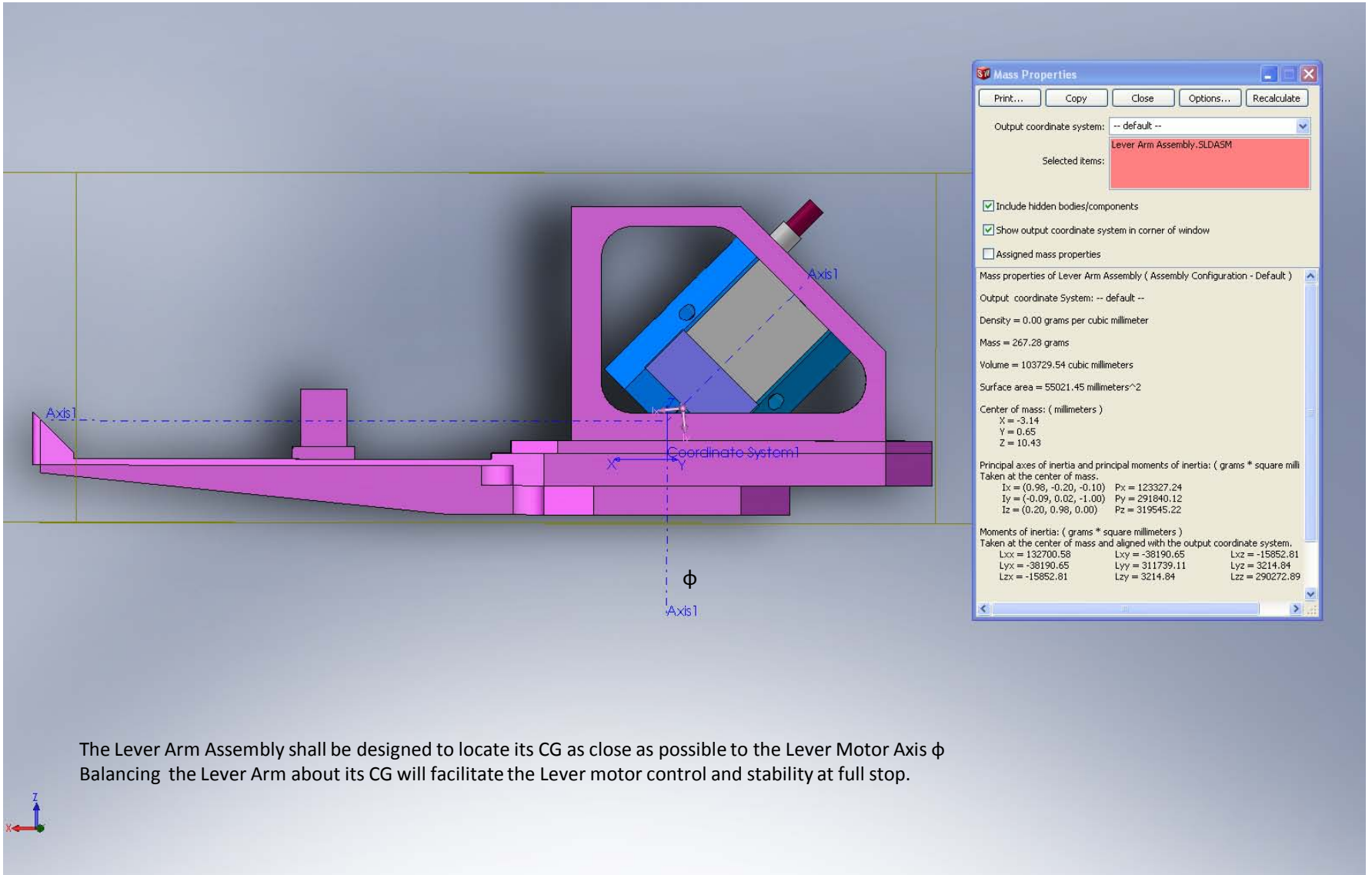

Remaining work to be done

- Choosing a probe Anti-collision System (Kaman?...)
- Analyze Tip/Tilt Mirror Vibrations and Impact on Probe stabilization.
- System rigidity Analysis
- System Integration within higher Assemblies
- Compare other motors and Tip / Tilt Mirrors.